

PROJECT: BOYLE		SHEET NO. 130
BY: CEF	DATE: 6/25/17	JOB NO. 17147

STRUCTURAL CALCULATIONS
FOR THE
BOYLE RESIDENCE
+
GARAGE
(3603 WEST MERCER WAY)

- JAMES GUERZEW ARCHITECTURE

DESIGN PARAMETERS: 2015 IBC
SEE NOTES ON "S1.0"

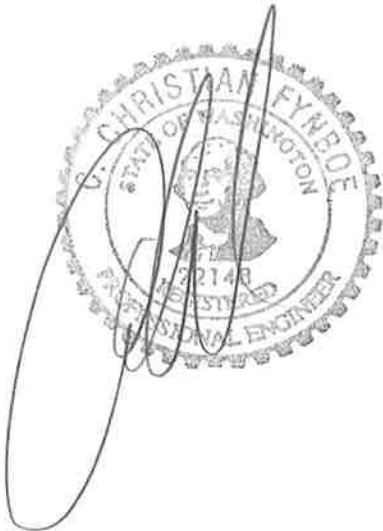

#1747 2/30

USGS Design Maps Summary Report

User-Specified Input

Building Code Reference Document 2009 NEHRP Recommended Seismic Provisions
(which utilizes USGS hazard data available in 2008)

Site Coordinates 47.57186°N, 122.23534°W

Site Soil Classification Site Class C – “Very Dense Soil and Soft Rock”

Risk Category I/II/III



USGS-Provided Output

$S_s = 1.411 \text{ g}$	$S_{MS} = 1.411 \text{ g}$	$S_{DS} = 0.941 \text{ g}$
$S_1 = 0.543 \text{ g}$	$S_{M1} = 0.705 \text{ g}$	$S_{D1} = 0.470 \text{ g}$

$CS = 1.94 / 6.5$
 $= .19$

For information on how the S_s and S_1 values above have been calculated from probabilistic (risk-targeted) and deterministic ground motions in the direction of maximum horizontal response, please [view the detailed report](#).

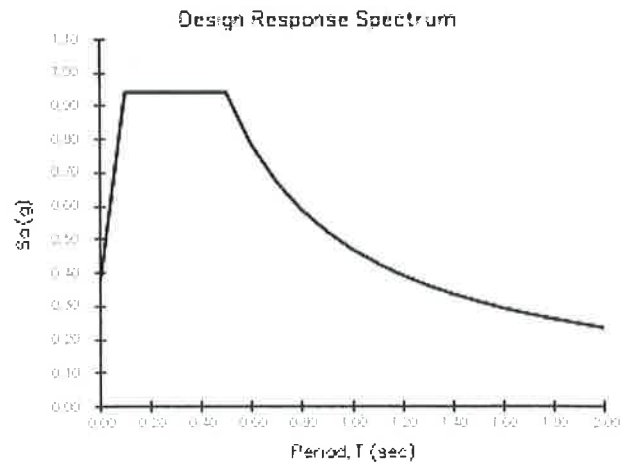
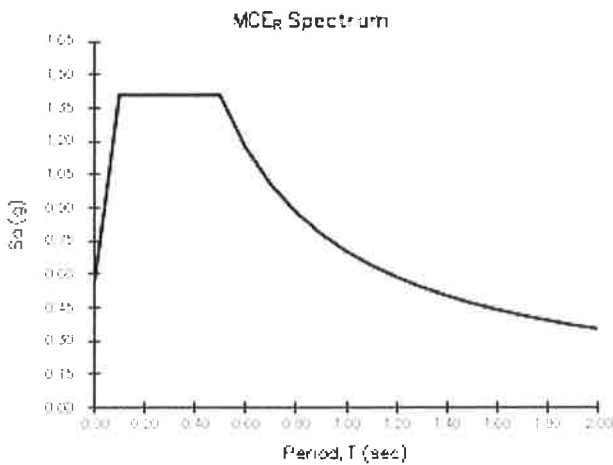

For PGA_M , T_L , C_{RS} , and C_{R1} values, please [view the detailed report](#).

Although this information is a product of the U.S. Geological Survey, we provide no warranty, expressed or implied, as to the accuracy of the data contained therein. This tool is not a substitute for technical subject-matter knowledge.

85mph BAPIC SEISMIC CAPD
 $\rho = 17.5 \text{ spst}$ HOUSE
 $V = 1.4 \text{ IN}$

#17197
 30

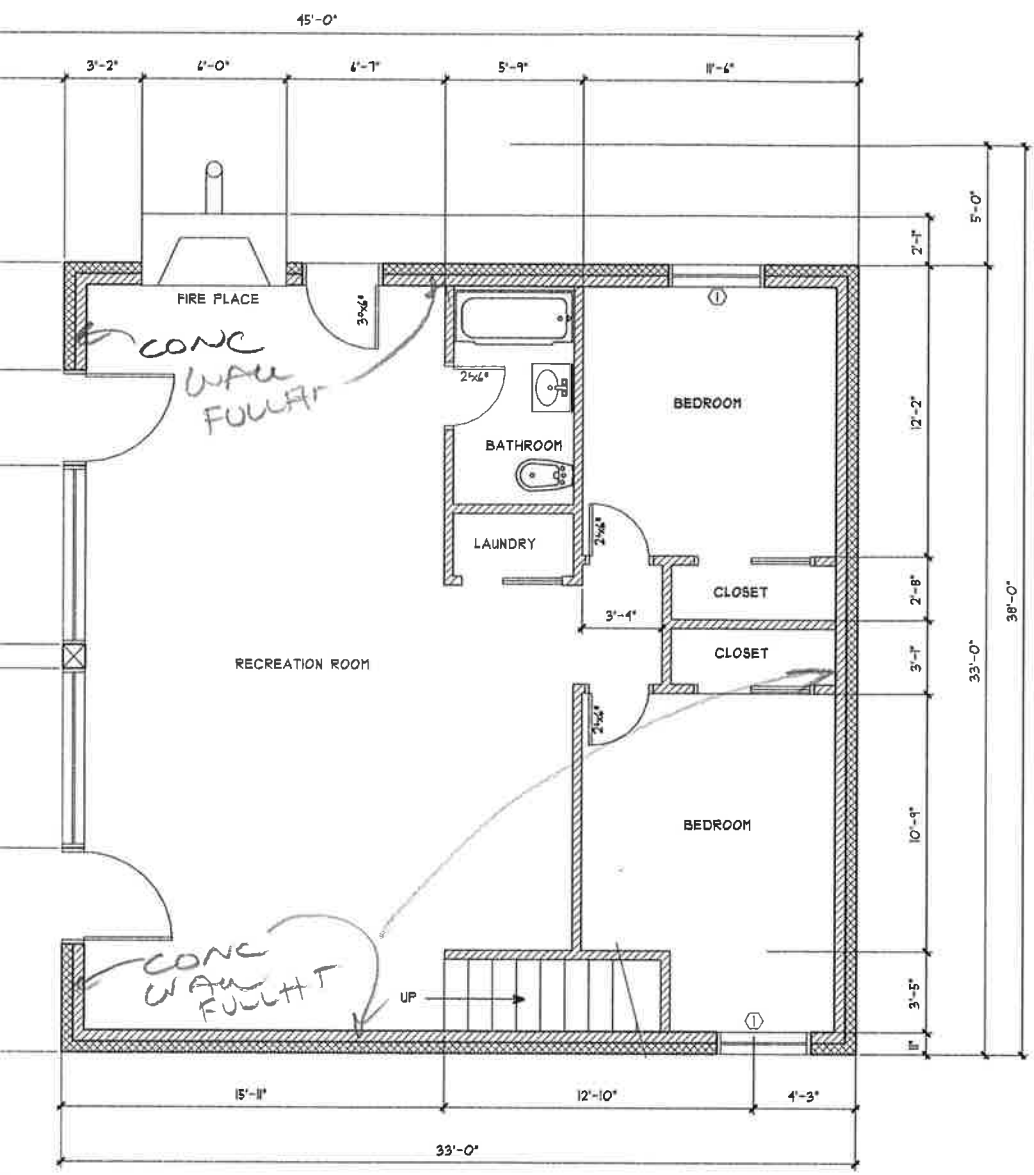

F3 ALL BASEMENT FLOOR PLAN

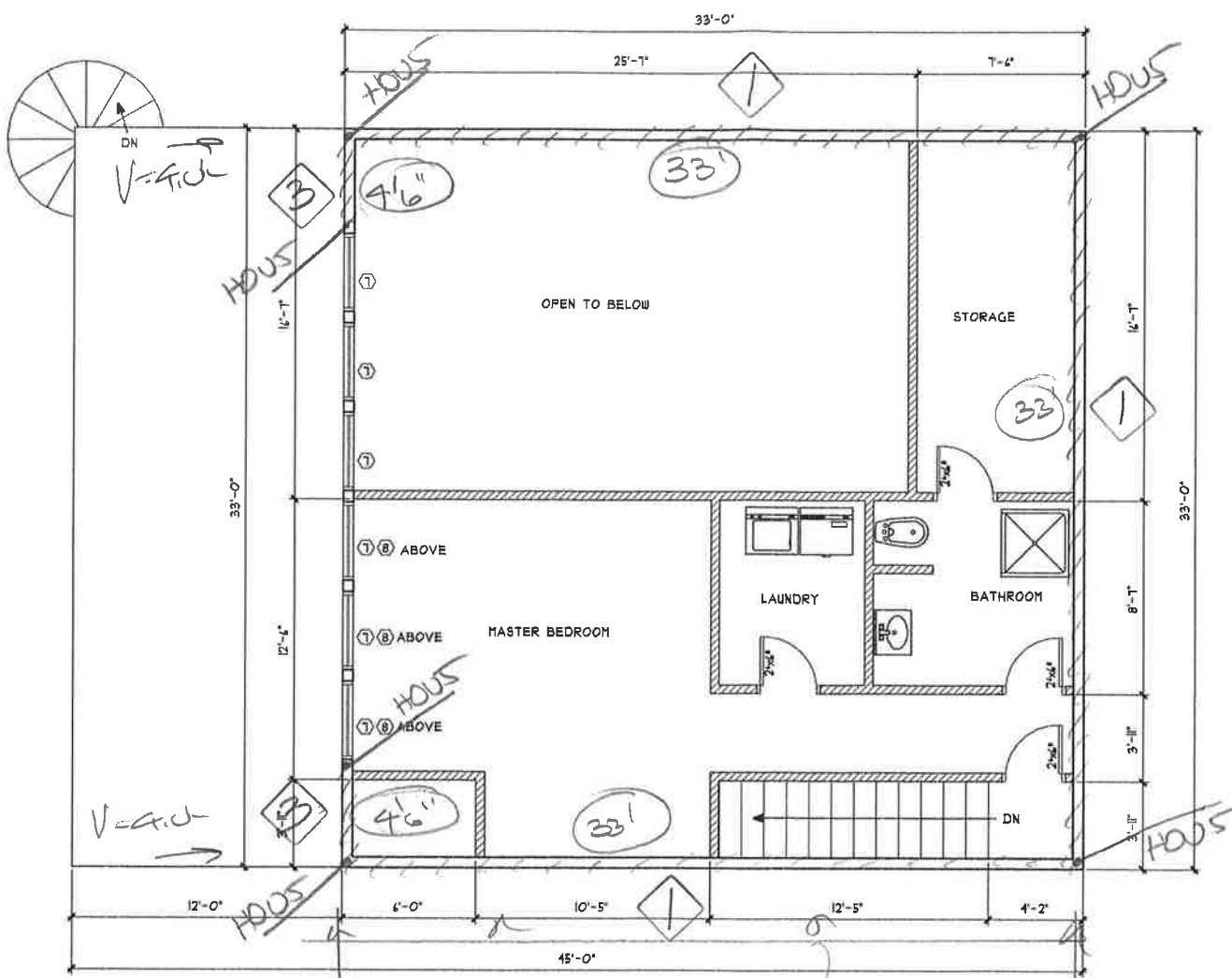

F1 ALL SECOND FLOOR PLAN

11150 Gravelly Lake Drive SW
 Lakewood, WA 98499
 Phone: 253/581-6000
 Website: www.jgarch.net

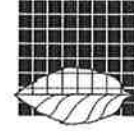

MERCER ISLAND

#1742 4/30

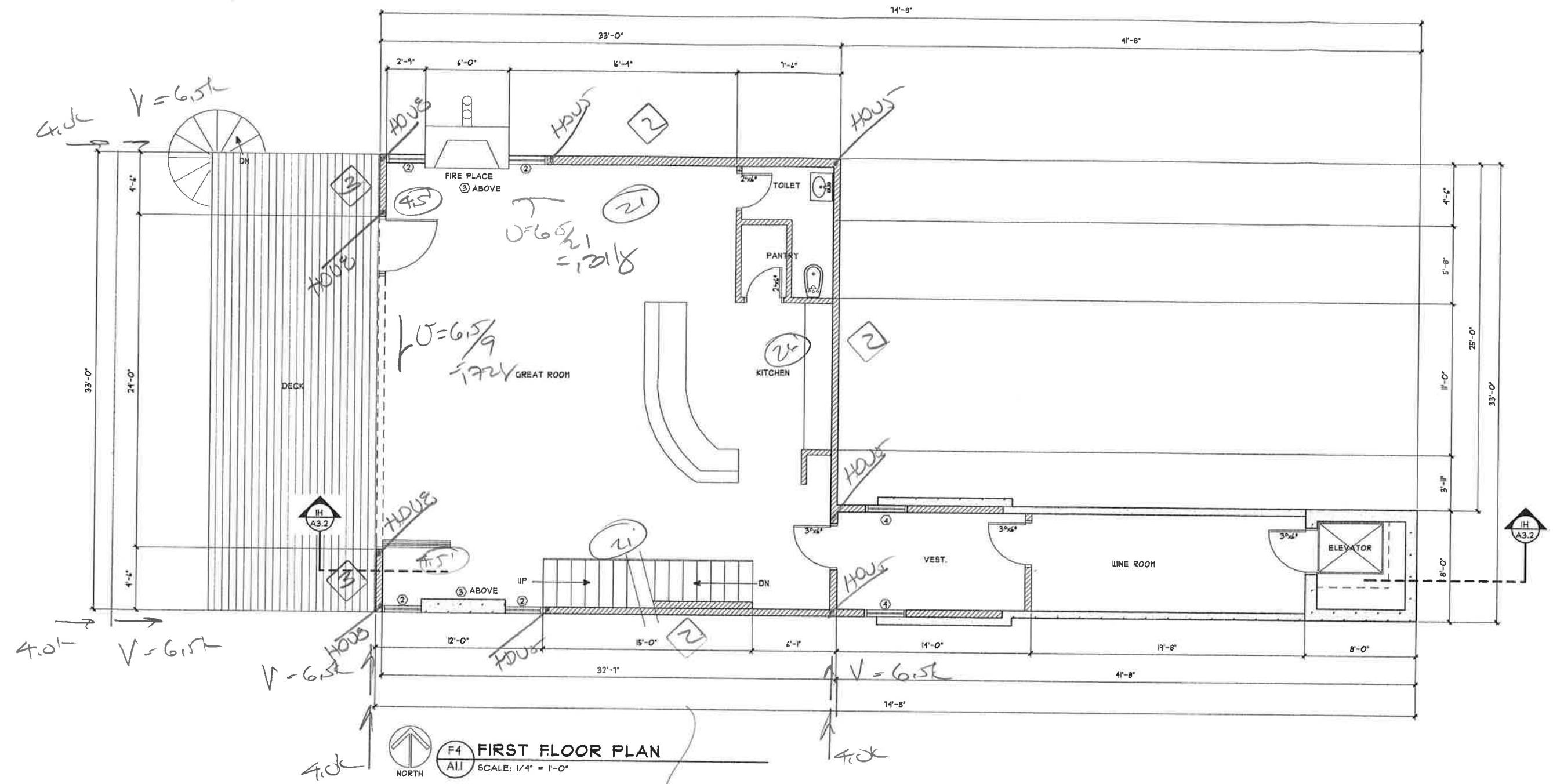

F4 FIRST FLOOR PLAN
 ALL SCALE: 1/4" = 1'-0"

FLOOR DIAPHRAGM
 3/4" T&G PN (48/24)
 Edge 6" x 6" PAPER EDGES
 & BOUNDARIES
 Edge 10" x 10" T&G
 GUARDRAILS

$W = 8.5(1075) = 115K$

PROJECT:			SHEET NO.
BY:	DATE:	JOB NO.	930
		17147	

Mark (shear capacity)	Wall Type (3)	Panel Edge Nailing (1), (2)	Intermediate Nailing (2)	Bottom Plate Anchor Bolting or Nailing (5)
1 (200 lb/ft.)	½" CDX Plywood or OSB, one side	8d @ 6" o.c.	8d @ 12" o.c.	½" A.B. @ 4'-0" o.c. or 16d @ 7½" o.c.
2 (350 lb/ft.)	½" CDX Plywood or OSB, one side	8d @ 4" o.c.	8d @ 12" o.c.	5/8" A.B. @ 3'-4" o.c. or 16d @ 4" o.c.
3 (700 lb/ft.)	½" CDX Plywood or OSB, both sides	8d @ 4" o.c. (4)	8d @ 12" o.c.	¾" A.B. @ 2'-0" o.c. or 16d @ 2" o.c.
11 (200 lb/ft.)	½" GWB, both sides	5d cooler nails @ 7" o.c.	5d cooler nails @ 7" o.c.	½" A.B. @ 4'-0" o.c. or 16d @ 8" o.c.

Notes:

1. Block all panel edges.
2. Common or box nails.
3. 2x studs shall be H.F. #2 or better, kiln-dried.
4. Use 3x studs and plates @ panel edges, wall type 3 only.
5. Anchor bolts shall have minimum 3" by 3" by ¼" thick plate washers.

PROJECT:		SHEET NO.	
BY:	DATE:	JOB NO.	6/30
		17147	

SHEAR WALL (HEM-FIR VALUES)

① $1\frac{5}{32}$ STRUCT I $8d @ 6" \llcorner 280(.82) = 230 \frac{lb}{ft}$
 $1/2" \phi AB @ 4'0" \llcorner 600(1.16/4) = 290 \frac{lb}{ft}$
 $16d @ 7\frac{1}{2}" \llcorner 91(1.16)1\frac{3}{4} = 233 \frac{lb}{ft}$
200 lb/ft

② $5\frac{1}{32}$ STRUCT I $8d @ 4" \llcorner 430(.82) = 353 \frac{lb}{ft}$
 $5/8" \phi AB @ 3'4" \llcorner 860(1.16) / 3.33 = 413 \frac{lb}{ft}$
 $16d @ 4" \llcorner 91(1.16)1\frac{3}{4} = 437 \frac{lb}{ft}$
350 lb/ft

③ $1\frac{5}{32}$ STRUCT I $8d @ 4" \llcorner 353(.82) = 706 \frac{lb}{ft}$
 $3/4" \phi AB @ 2'0" \llcorner 1150(1.16) / 2 = 944 \frac{lb}{ft}$
 $16d @ 2" \llcorner 91(1.16)1\frac{3}{4} = 873 \frac{lb}{ft}$
700 lb/ft

PROJECT:		SHEET NO.
BY:	DATE:	JOB NO. 1714
		7/30

ROOF FRAMING

$l = 32'$

$W = .045(14) = 1.728$ $R = 11.5k$

$M = \frac{1.72(32)^2}{8} = 1106 k''$

$S_{req} = \frac{1106}{2.4(1.15)} = 401 in^3$

$I_{req} = \frac{5}{384} \frac{(1.72)(32)^4(1.728)}{1800(1.16)} = 5898 in^4$
5'8" x 24" C

2ND FLOOR

$l = 32'$

$W = .05(10) = 0.5k$ $R = 8k$

$M = \frac{0.5(32)^2}{8} = 768 k''$

$S_{req} = \frac{768}{2.4} = 320 in^3$

$I_{req} = \frac{5}{384} \frac{(0.5)(32)^4(1.728)}{1800(1.11)} = 5957$
5'8" x 24" C

PROJECT:			SHEET NO.
BY:	DATE:	JOB NO.	01/30
		1214	

$$l = 24'$$

14.4

$$W = 0.45(10) = 4.5 \text{ k}$$

$$P = 8.0 \text{ k}$$

$$M = \left[\frac{4.5(24)^2}{8} + \frac{8.0(24)}{4} \right] 12 = 965 \text{ k-in}$$

$$\text{Saves } \frac{965}{24(1.15)} = 350 \text{ -}$$

$$5\frac{1}{2}' \times 24' \text{ C}$$

PROJECT:			SHEET NO. 9/30
BY:	DATE:	JOB NO. 17142	

STAIR

l = 12'

$$W = .065(6) + 1.05(10) = 1.89 \text{ k} \quad 12 - 5.3 \text{ k}$$

$$M = \frac{1.89(12)^2}{8} = 192 \text{ k}'$$

$$S_{req} = \frac{192}{2.4} = 80.1$$

5" x 12"

l = 21' floor

$$W = .05(16 \text{ ft}) = 1.0667 \text{ k}$$

$$M = \frac{1.0667(21)^2}{8} = 377 \text{ k}'$$

USE 14" TJI/PB340
0.16"

l = 11' DECK

$$W = .065(6) = 1.39 \text{ k}$$

$$M = \frac{1.39(11)^2}{8} = 71 \text{ k}'$$

$$S_{req} = \frac{71}{1.675} = 105$$

TJI 6x12

$$P = 1.39(11) = 4.3 \text{ k}$$

$$L = \sqrt{\frac{4.3 \times 1.3}{3 \times 0.4 \times 12}} = 1.3'$$

FR

A17142
10/30

Design Properties (100% Load Duration)

Depth	TJI®	Basic Properties				Reaction Properties		
		Joist Weight (lbs/ft)	Maximum Resistive Moment ⁽¹⁾ (ft-lbs)	Joist Only EI x 10 ⁶ (in. ² -lbs)	Maximum Vertical Shear (lbs)	1 1/4" End Reaction (lbs)	3 1/2" Intermediate Reaction (lbs)	
						No Web Stiffeners	With Web Stiffeners	
9 1/2"	110	2.3	2,380	140	1,220	885	1,935	N.A.
	210	2.6	2,860	167	1,330	980	2,145	N.A.
	230	2.7	3,175	183	1,330	1,035	2,410	N.A.
11 1/8"	110	2.5	3,015	238	1,560	885	1,935	2,295
	210	2.8	3,620	283	1,655	980	2,145	2,505
	230	3.0	4,015	310	1,655	1,035	2,410	2,765
	360	3.0	6,180	419	1,705	1,080	2,460	2,815
14"	560	4.0	9,500	636	2,050	1,265	3,000	3,475
	110	2.8	3,565	351	1,860	885	1,935	2,295
	210	3.1	4,280	415	1,945	980	2,145	2,505
	230	3.3	4,755	454	1,945	1,035	2,410	2,765
16"	360	3.3	7,335	612	1,955	1,080	2,460	2,815
	560	4.2	11,275	926	2,390	1,265	3,000	3,475
	210	3.3	4,895	566	2,190	980	2,145	2,505
	230	3.5	5,440	618	2,190	1,035	2,410	2,765
16"	360	3.5	8,405	830	2,190	1,080	2,460	2,815
	560	4.5	12,925	1,252	2,710	1,265	3,000	3,475

(1) Caution: Do not increase joist moment design properties by a repetitive member use factor.

General Notes

- Design reaction includes all loads on the joist. Design shear is computed at the inside face of supports and includes loads on the span(s). Allowable shear may sometimes be increased at interior supports in accordance with ICC ES ESR-1153, and these increases are reflected in span tables.
- The following formulas approximate the uniform load deflection of Δ (inches):

TJI® joists are intended for dry-use applications

For
TJI® 110, 210, 230, and 360 Joists

$$\Delta = \frac{22.5 wL^4}{EI} + \frac{2.67 wL^2}{d \times 10^5}$$

w = uniform load in pounds per linear foot
L = span in feet
d = out-to-out depth of the joist in inches
EI = value from table above

For
TJI® 560 Joists

$$\Delta = \frac{22.5 wL^4}{EI} + \frac{2.29 wL^2}{d \times 10^5}$$

Material Weights

(Include TJI® weights in dead load calculations—see Design Properties table at left for joist weights)

Floor Panels

Southern Pine

1/2" plywood	1.7 psf
5/8" plywood	2.0 psf
3/4" plywood	2.5 psf
1 1/8" plywood	3.8 psf
1/2" OSB	1.8 psf
5/8" OSB	2.2 psf
3/4" OSB	2.7 psf
7/8" OSB	3.1 psf
1 1/8" OSB	4.1 psf

Based on: Southern pine – 40 pcf for plywood, 44 pcf for OSB

Roofing

Asphalt shingles	2.5 psf
Wood shingles	2.0 psf
Clay tile	9.0 to 14.0 psf
Slate (3/8" thick)	15.0 psf

Roll or Batt Insulation (1" thick):

Rock wool	0.2 psf
Glass wool	0.1 psf

Floor Finishes

Hardwood (nominal 1")	4.0 psf
Sheet vinyl	0.5 psf
Carpet and pad	1.0 psf
3/4" ceramic or quarry tile	10.0 psf

Concrete:

Regular (1")	12.0 psf
Lightweight (1")	8.0 to 10.0 psf
Gypsum concrete (3/4")	6.5 psf

Ceilings

Acoustical fiber tile	1.0 psf
1/2" gypsum board	2.2 psf
5/8" gypsum board	2.8 psf
Plaster (1" thick)	8.0 psf

TABLE OF CONTENTS

Design Properties	3	Silent Floor® Joist Framing	8	Understanding and Preventing Floor Noise	15
Material Weights	3	Floor Details	9	Roof Span Table	16–17
Floor Span Tables	4	Fastening of Floor Panels	9	Cut Length Calculation and Factor Tables	17
Floor Load Tables	5	Rim Board Selection and Installation	10	Roof Framing	18
PSF to PLF Conversion Table	5	Allowable Holes	11	Roof Details	19–20
Floor Performance	6	Cantilevers	12–13	Roof Load Tables	21
FrameWorks® Floor	7	Fire-Safe Construction	14	Framing Connectors	22–23

DTT Deck Tension Ties



DTT tension ties are safe, cost-effective connectors designed to meet or exceed code requirements for deck construction. These versatile DTT connectors are also load rated as a holddown for light-duty shearwalls and braced wall panel applications.

For new construction or to make an existing current deck code-compliant, the DTT1Z can be used as a tension-tie to satisfy the 2015 IRC provision for a 750 lbs. lateral load connection to the house at four locations per deck. This new code detail permits the lateral connection from the deck joists to be made to top plates, studs, or headers within the supporting structure, which eliminates the need to access to the floor joists inside the home.

The new DTT1Z fastens to the narrow or wide face of a single 2x with Simpson Strong-Tie® Strong-Drive® SD Connector screws or nails and accepts a 3/8" machine bolt, anchor bolt, or lag screw (washer required) or can be installed with the new Strong-Drive SDWH Timber-Hex HDG screw with an integral washer. The DTT2 fastens easily to the wide face of a single or double 2x using Simpson Strong-Tie Strong-Drive SDS Heavy-Duty Connector screws (included) and accepts a 1/2" machine bolt or anchor bolt.

The DTT2 can be used to satisfy the IRC provision for a 1,500 lbs. lateral load connection at two locations per deck. Additionally, the DTT2 has been tested and evaluated in deck guardrail post applications to resist the code-specified lateral forces at the top of railing assemblies. The DTT2 is also available with longer 2 1/2" Strong-Drive SDS Heavy-Duty Connector screws (model DTT2Z-SDS2.5) to achieve higher loads when needed.

MATERIAL: 14 gauge

FINISH: DTT1Z/DTT2Z—ZMAX® coating;

DTT2SS—Stainless steel; see Corrosion Information, pages 13-15.

INSTALLATION:

- Use all specified fasteners. See General Notes.
- A standard cut washer (included) must be installed between the nut and the seat.
- Simpson Strong-Tie Strong-Drive SDS Heavy-Duty Connector screws install best with a low speed high torque drill with a 3/8" hex head driver.
- Strong-Drive SD Connector screws install with a 1/4" hex head driver.
- Strong-Drive SDWH Timber-Hex HDG screws install with a 1/2" hex head driver.

CODES: See page 12 for Code Reference Key Chart.

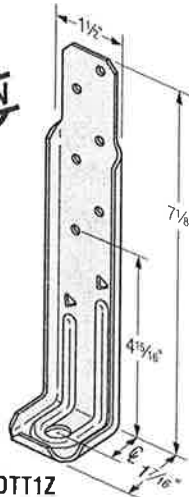

DTT1Z

U.S. Patent Pending

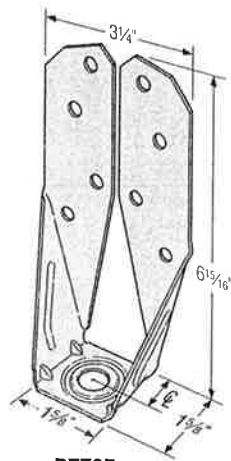

DTT2Z

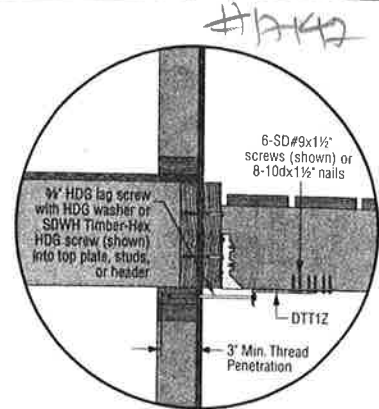

Typical DTT1Z Deck-to-House Lateral Load Connection

For more information on lateral load connections, see technical bulletin T-DECKLATLOAD

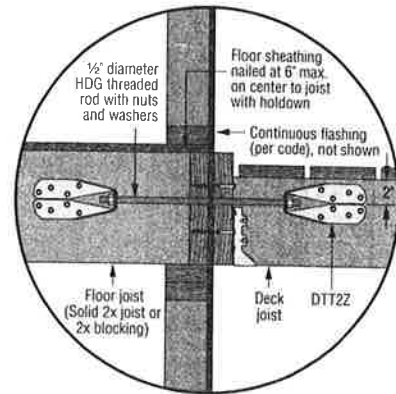

Typical DTT2Z Deck-to-House Lateral Load Connection

For more information on lateral load connections, see technical bulletin T-DECKLATLOAD

These products are available with additional corrosion protection. Additional products on this page may also be available with this option, check with Simpson Strong-Tie for details.

Model No.	Ø	Anchor Dia.	Fasteners	Minimum Wood Member Thickness	Allowable Tension Loads		Code Ref.
					DF/SP	SPF/HF	
DTT1Z	3/8"	3/8" or SDWH ³	6-SD #9x1 1/2"	1 1/2"	840	840	160
			6-10dx1 1/2"		910	640 ⁴	
			8-10dx1 1/2"		910	350	
DTT2Z/DTT2SS	1/2"	1/2"	8-1/4"x1 1/2" SDS	1 1/2"	1825	1800	16, L8, F5
					3"	2145	
DTT2Z-SDS2.5	1/2"	1/2"	8-1/4"x2 1/2" SDS	3"	2145	2105	

1. Allowable loads have been increased 60% for wind or earthquake loading with no further increase allowed.
2. DTT1Z installations with allowable loads below 750 lbs. do not satisfy the 2015 IRC requirements for deck-to-house lateral load connections.
3. The Strong-Drive® SDWH Timber-Hex HDG screw with a minimum of 3" of thread penetration into dry lumber has an allowable withdrawal load (160) of 1380 lbs. into SP, 1225 lbs. into DF and 1020 lbs. into SPF/HF.
4. Load values are valid if the product is flush with the end of the framing member or installed away from the end.
5. The guardrail post illustration above addresses an outward force on the guardrail. An additional DTT2Z can be added at the lower bolt to address an inward force.
6. A 3/4" HDG round washer is required when using a lag screw.

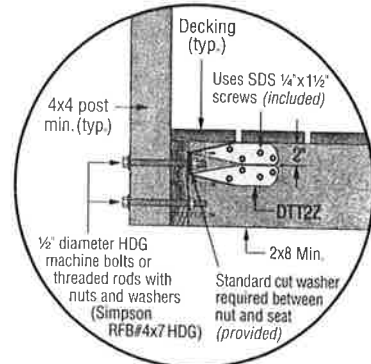

DTT2Z Installed as a Lateral Connector for a Deck Guardrail Post

For more information on guardrail post connections, see technical bulletin T-GRDRLPST

#1742 12/30

10" Conc w/ #5 @ 10.in o/c

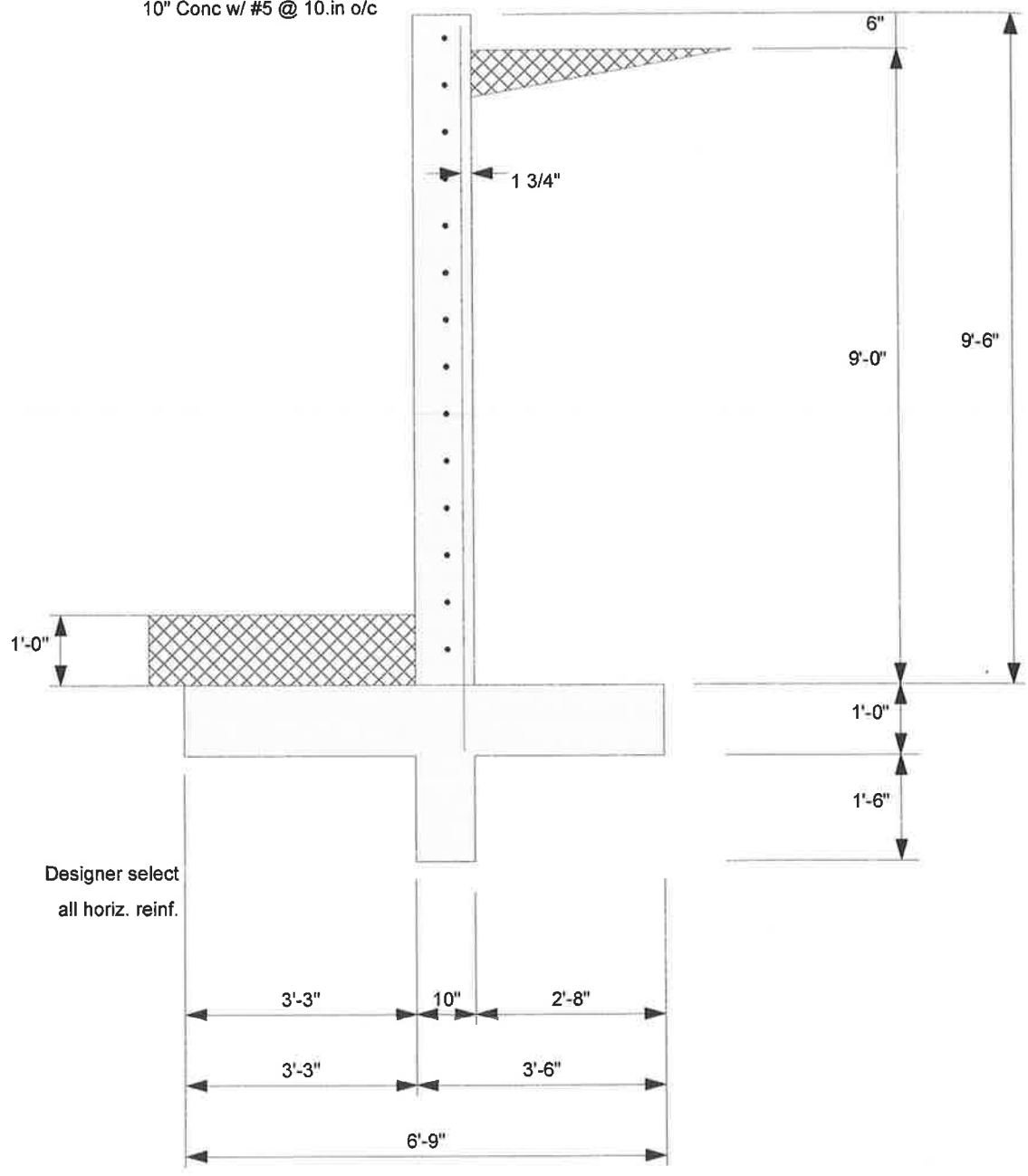

#17147 13/30

CANTILEVERED RETAINING WALL DESIGN

GENERAL

Retained Height	=	9.00 ft
Wall height above retained soil	=	0.50 ft
Slope Behind Wall	=	0.00 : 1
Height of Soil over Toe	=	12.00 in
Soil Density	=	120.00 pcf

SOIL DATA

Allow Soil Bearing	=	2,500.0 psf
Equivalent Fluid Pressure Method		
Active Soil Pressure - Heel Side	=	55.0 psf
Active Soil Pressure - Toe Side	=	55.0 pcf
Passive Pressure	=	300.0 pcf
Water table height over heel	=	0.0 ft

FOOTING DATA

Toe Width	=	3.25 ft
Heel Width	=	3.50
Total Footing Width	=	6.75
Footing Thickness	=	12.00 in

SLIDING DATA

Friction Factor @ Footing & Soil	=	0.400
...neglect ht. for passive	=	0.00 in
Lateral Sliding Force	=	2,640.0
less Passive Pressure Force	=	- 1,837.5 lbs
less Friction Force	=	- 2,263.0 lbs
Added Restraint Force Required	=	0.0 lbs

KEY DATA

Distance from Toe	=	3.25 ft
Width	=	10.00 in
Depth	=	18.00 in

FOOTING DESIGN RESULTS

fc	=	3,000 psi
Fy	=	60,000 psi
Minimum As %	=	0.0018
Rebar Cover @ Top	=	2.00 in
Rebar Cover @ Bottom	=	3.00 in

Minimum Footing Rebar Options.....

Toe Side.....	Heel Side....
# 4 @ 10.50 in	# 4 @ 11.75 in
# 5 @ 16.25 in	# 5 @ 18.25 in
# 6 @ 23.00 in	# 6 @ 25.75 in
# 7 @ 31.25 in	# 7 @ 35.25 in
# 8 @ 41.25 in	# 8 @ 46.25 in
# 9 @ 48.25 in	# 9 @ 48.25 in
# 10 @ 48.25 in	# 10 @ 48.25 in

	Toe	Heel
ACI Factored Soil Pressure	= 1,818	529 psf
Mu' : From Upward Loads	= 8,508	0 ft-#
Mu' : From Downward Loads	= 1,996	6,123 ft-#
Mu: Used For Design	= 6,511	6,123 ft-#
Actual One-Way Shear	= 29.83	40.28 psi
Allowable One-Way Shear	= 93.11	93.11 psi

Key Reinforcement: Not Req'd = Mu < S*Fr

DESIGN SUMMARY

Total Bearing Load	=	5,657 lbs
...resultant ecc.	=	7.41 in

Summary of Stem Section Designs....

Top: 10 in Conc, #5@10.00 in@Edge, From 9.5 ft to 0.0 ft

Soil Pressure @ Toe	=	1,298	<=	2,500 psf
Soil Pressure @ Heel	=	378	<=	2,500 psf
ACI Factored Press @ Toe	=	1,818 psf		
ACI Factored Press @ Heel	=	529 psf		
Footing Shear @ Toe	=	29.8	<=	93.1 psi
Footing Shear @ Heel	=	40.3	<=	93.1 psi

WALL STABILITY RATIOS				
Overtuning Stability Ratio	=	2.72		
Sliding Ratio Ratio	=	1.55		

#17147 14/30

CANTILEVERED RETAINING WALL DESIGN

SUMMARY OF OVERTURNING & RESISTING FORCES & MOMENTS

ItemOVERTURNING.....		RESISTING.....		
	Force lbs	Distance ft	Moment ft-#	Force lbs	Distance ft	Moment ft-#
Heel Active Pressure	= 2,750.0	3.33	9,166.7			
Soil Over Heel				2,880.0	5.42	15,600.0
Sloped Soil Over Heel	=					
Surcharge Over Heel	=					
Adjacent Footing Load	=					
Axial Dead Load on Stem	=				0.00	
Toe Active Pressure	= -110.0	0.67	-73.3			
Soil Over Toe				390.0	1.63	633.8
Surcharge Over Toe	=					
Stem Weight(s)	=			1,187.5	3.67	4,354.2
Earth @ Stem Transitions	=					
Footing Weight	=			1,012.5	3.38	3,417.2
Key Weight	=			187.5	3.67	687.5
Vert. Component	=					
Added Lateral Load	=					
Load @ Stem Above Soil	=					
TOTALS	= 2,640.0	O.T.M. =	9,093.3	5,657.5	R.M. =	24,692.6

Vertical component of active pressure used for soil pressure

Toe Surcharge Not Used To Resist Overturning

Heel Surcharge Not Used To Resist Overturning

Resisting/Overturning Ratio = 2.72

STEM CONSTRUCTION & DESIGN

Top Stem

Stem OK	=	
Design at this height above ftg	=	0.00 ft
Wall Material Above "Ht"	=	Concrete
Thickness	=	10.00 in
Rebar Size	=	# 5
Rebar Spacing	=	10.00 in
Rebar Placed at	=	Edge

Design Data

fb/FB + fa/Fa	=	0.866
Total Force @ Section	=	3,740.0 lbs
Moment.....Actual	=	11,344.7 ft-#
Moment.....Allowable	=	13,093.5 ft-#
Shear.....Actual	=	38.07 lbs
Shear.....Allowable	=	93.11 psi
Bar Embed ABOVE Ht.	=	14.14 in
Bar Embed BELOW Ht.	=	8.25 in
Wall Weight	=	125.0 psf
Rebar Depth 'd'	=	8.19 in

Masonry Data

fm	=	
Fs	=	
Solid Grouting	=	
Special Inspection	=	
Modular Ratio 'n'	=	
Short Term Factor	=	
Equiv. Solid Thick.	=	

Concrete Data

fc	=	3,000 psi
Fy	=	60,000 psi

#1743 157
30

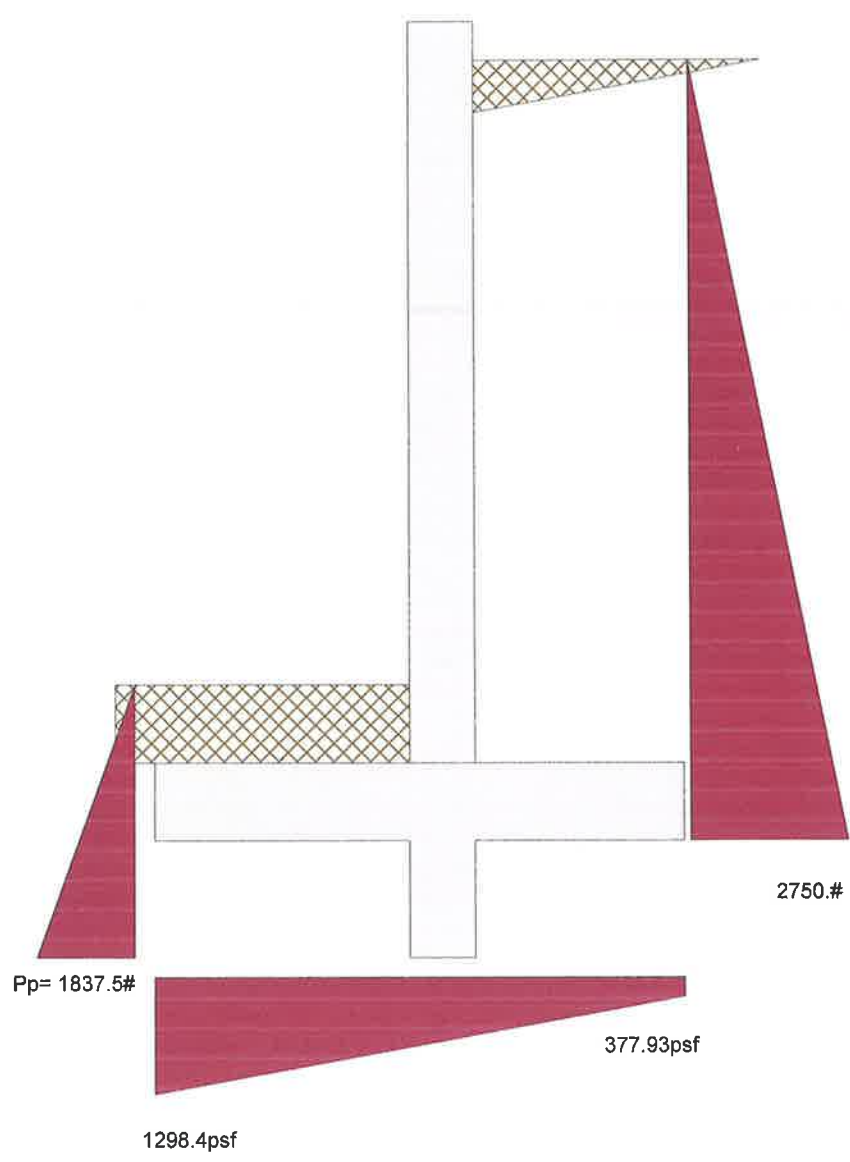

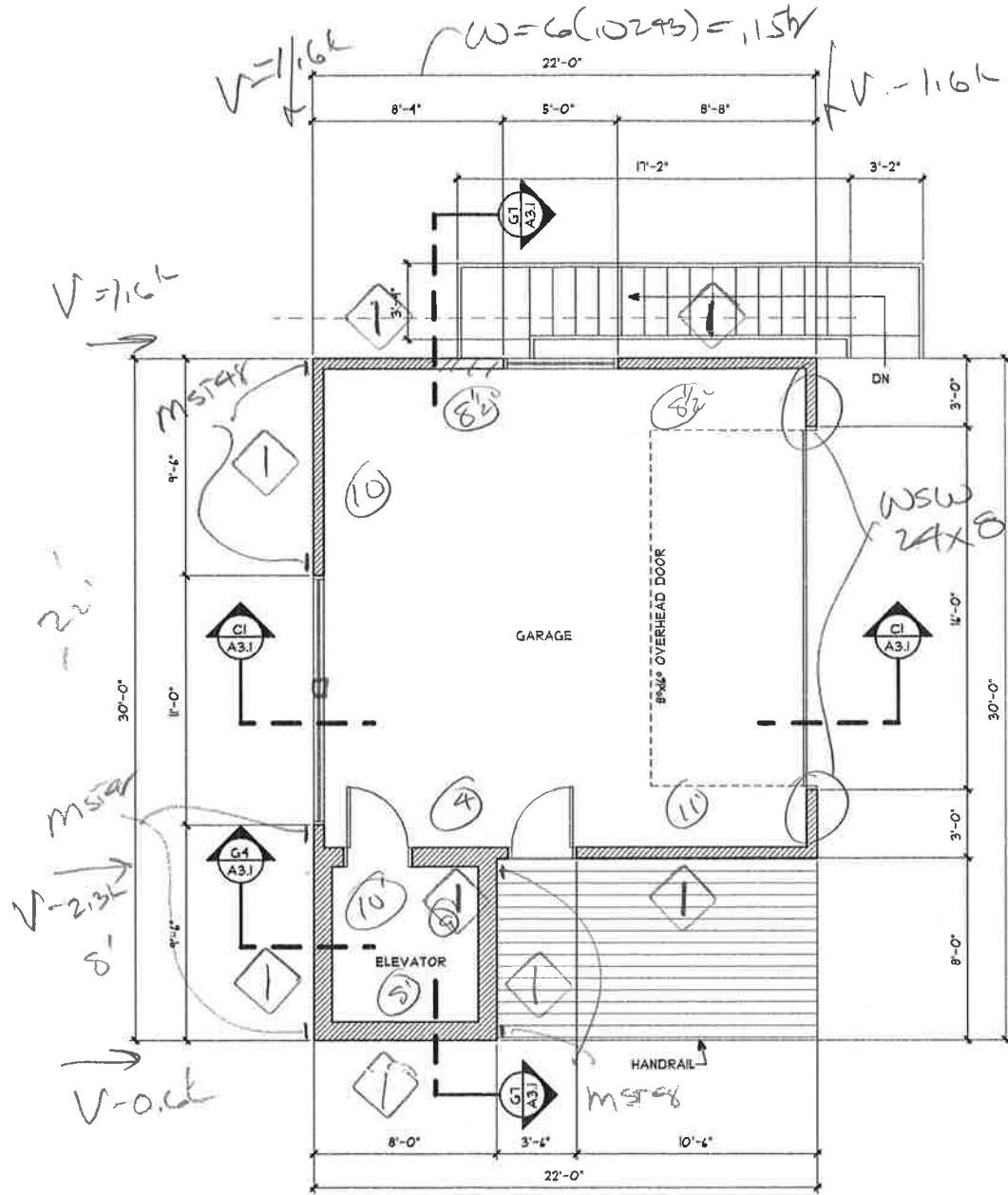

F2 GARAGE FLOOR PLAN
SCALE: 1/4" = 1'-0"
NORTH

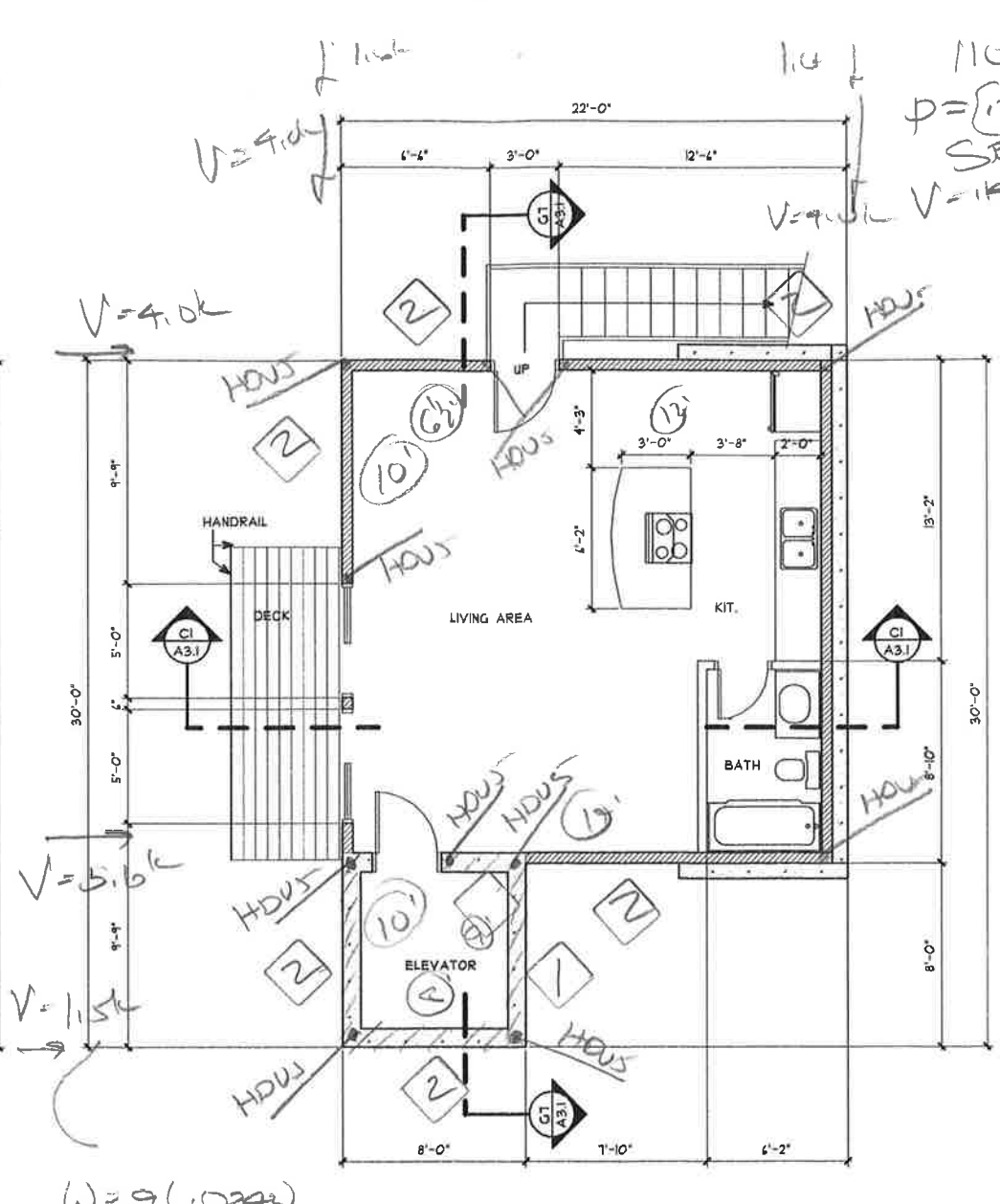

F5 APARTMENTS FLOOR PLAN
SCALE: 1/4" = 1'-0"
NORTH

110mpd Ex 0'6" K2T=2.0 GARAGE
 $P = [12(35.7) + 1.8(23.7)] / 6(1.55) = 293\text{psf}$
 SEISMIC CAT 10
 $V = 1.41W$

#17147

16/30

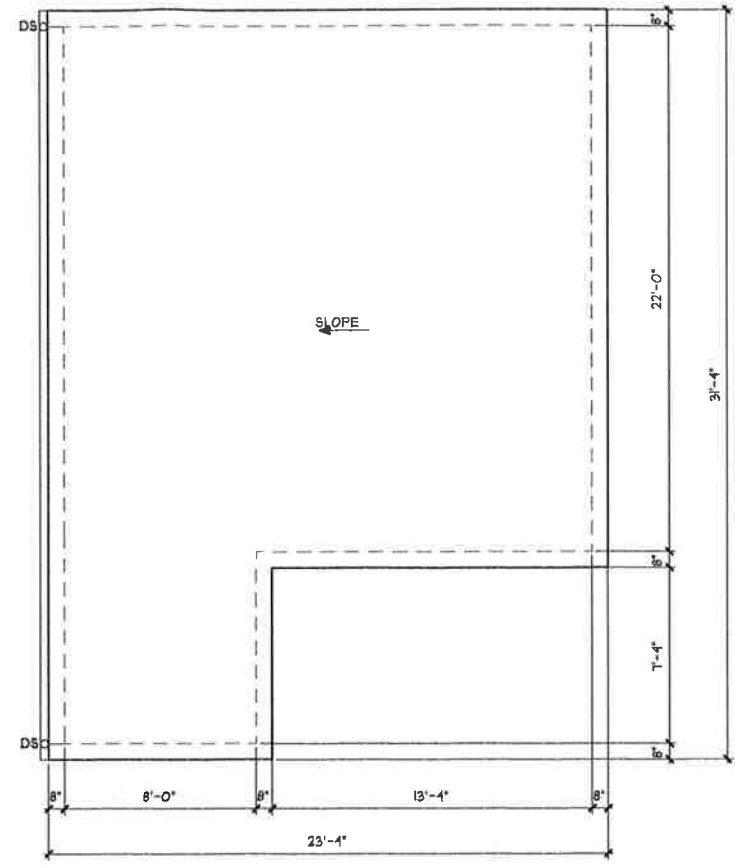

F8 ROOF PLAN
SCALE: 1/4" = 1'-0"
NORTH

ROOF DIAPHRAGM
 1/2" DW (32/16)
 Edge 6" PANEL FLOOR
 FROM TRIMMES
 Edge 2" FINS

FLOOR DIAPHRAGM
 1 1/2" DW (48/24)
 10' x 6" PANEL FLOOR
 FROM TRIMMES
 10' x 10" FINS
 GWS & NAILS

11150 Gravelly Lake Drive SW
 Lakewood, WA 98499
 Phone: 253/581-6000
 Website: www.jgarth.net

Standard and Balloon Framing on Concrete Foundations

#17192 13/30

Strong-Wall® Wood Shearwall Standard Application on Concrete Foundation

Strong-Wall Wood Shearwall Model ¹	Allowable Vertical Load, P (lb.) ⁴	2,500 psi Concrete						3,000 psi Concrete					
		Seismic ³			Wind			Seismic ³			Wind		
		Allowable ASD Shear Load, V (lb.)	Drift at Allowable Shear, Δ (in.) ¹⁰	Anchor Tension at Allowable Shear, T (lb.) ¹¹	Allowable ASD Shear Load, V (lb.)	Drift at Allowable Shear, Δ (in.) ¹⁰	Anchor Tension at Allowable Shear, T (lb.) ¹¹	Allowable ASD Shear Load, V (lb.)	Drift at Allowable Shear, Δ (in.) ¹⁰	Anchor Tension at Allowable Shear, T (lb.) ¹¹	Allowable ASD Shear Load, V (lb.)	Drift at Allowable Shear, Δ (in.) ¹⁰	Anchor Tension at Allowable Shear, T (lb.) ¹¹
WSW12x7	1,000	1,065	0.31	10,285	1,380	0.43	13,375	1,065	0.31	10,285	1,380	0.43	13,375
	4,000	1,065	0.31	10,285	1,380	0.43	13,375	1,065	0.31	10,285	1,380	0.43	13,375
	7,500	1,065	0.31	10,285	1,380	0.43	13,370	1,065	0.31	10,285	1,380	0.43	13,375
WSW18x7	1,000	2,475	0.31	13,865	2,980	0.4	16,675	2,475	0.31	13,865	3,225	0.43	18,040
	4,000	2,475	0.31	13,865	2,710	0.36	15,160	2,475	0.31	13,865	3,225	0.43	18,040
	7,500	2,475	0.31	13,865	2,395	0.32	13,395	2,475	0.31	13,865	2,910	0.39	16,280
WSW24x7 ⁹	1,000	5,515	0.29	22,710	5,515	0.32	22,710	5,515	0.29	22,710	5,515	0.32	22,710
	4,000	5,515	0.29	22,710	5,400	0.31	22,240	5,515	0.29	22,710	5,515	0.32	22,710
	7,500	5,515	0.29	22,710	4,950	0.29	20,390	5,515	0.29	22,710	5,515	0.32	22,710
WSW12x8	1,000	960	0.39	11,125	1,245	0.53	14,420	960	0.39	11,125	1,245	0.53	14,420
	4,000	960	0.39	11,125	1,245	0.53	14,420	960	0.39	11,125	1,245	0.53	14,420
	7,500	960	0.39	11,125	1,155	0.49	13,370	960	0.39	11,125	1,245	0.53	14,420
WSW18x8	1,000	2,430	0.39	16,245	2,490	0.42	16,675	2,430	0.39	16,245	2,925	0.50	19,560
	4,000	2,430	0.39	16,245	2,265	0.38	15,160	2,430	0.39	16,245	2,695	0.46	18,045
	7,500	2,430	0.39	16,245	2,000	0.34	13,395	2,430	0.39	16,245	2,435	0.41	16,280
WSW24x8	1,000	4,945	0.37	24,355	4,840	0.40	23,830	4,945	0.37	24,355	5,515	0.45	27,150
	4,000	4,945	0.37	24,355	4,515	0.37	22,240	4,945	0.37	24,355	5,360	0.44	26,395
	7,500	4,945	0.37	24,355	4,140	0.34	20,390	4,945	0.37	24,355	4,985	0.41	24,540
WSW12x9	1,000	790	0.43	10,310	1,020	0.60	13,335	790	0.43	10,310	1,020	0.60	13,335
	4,000	790	0.43	10,310	1,020	0.60	13,335	790	0.43	10,310	1,020	0.60	13,335
	7,500	790	0.43	10,310	1,020	0.60	13,335	790	0.43	10,310	1,020	0.60	13,335
WSW18x9	1,000	1,920	0.43	14,505	2,210	0.53	16,675	1,920	0.43	14,505	2,515	0.60	18,980
	4,000	1,920	0.43	14,505	2,010	0.48	15,160	1,920	0.43	14,505	2,390	0.57	18,045
	7,500	1,920	0.43	14,505	1,775	0.42	13,395	1,920	0.43	14,505	2,155	0.51	16,280
WSW24x9	1,000	4,190	0.43	23,275	4,290	0.46	23,830	4,190	0.43	23,275	5,035	0.54	27,985
	4,000	4,190	0.43	23,275	4,000	0.43	22,240	4,190	0.43	23,275	4,750	0.51	26,395
	7,500	4,190	0.43	23,275	3,670	0.40	20,390	4,190	0.43	23,275	4,415	0.48	24,540
WSW12x10	1,000	630	0.50	9,175	810	0.67	11,810	630	0.50	9,175	810	0.67	11,810
	4,000	630	0.50	9,175	810	0.67	11,810	630	0.50	9,175	810	0.67	11,810
	7,500	630	0.50	9,175	810	0.67	11,810	630	0.50	9,175	810	0.67	11,810
WSW18x10	1,000	1,715	0.49	14,440	1,980	0.59	16,675	1,715	0.49	14,440	2,225	0.67	18,715
	4,000	1,715	0.49	14,440	1,800	0.54	15,160	1,715	0.49	14,440	2,145	0.64	18,045
	7,500	1,715	0.49	14,440	1,590	0.48	13,395	1,715	0.49	14,440	1,935	0.58	16,280
WSW24x10	1,000	3,675	0.48	22,740	3,850	0.54	23,830	3,675	0.48	22,740	4,520	0.63	27,985
	4,000	3,675	0.48	22,740	3,590	0.50	22,240	3,675	0.48	22,740	4,265	0.60	26,395
	7,500	3,675	0.48	22,740	3,295	0.46	20,390	3,675	0.48	22,740	3,965	0.55	24,540
WSW12x11	1,000	575	0.55	9,190	735	0.73	11,810	575	0.55	9,190	735	0.73	11,810
	4,000	575	0.55	9,190	735	0.73	11,810	575	0.55	9,190	735	0.73	11,810
	7,500	575	0.55	9,190	735	0.73	11,810	575	0.55	9,190	735	0.73	11,810
WSW18x11	1,000	1,510	0.53	14,010	1,800	0.67	16,675	1,510	0.53	14,010	1,975	0.73	18,335
	4,000	1,510	0.53	14,010	1,635	0.61	15,160	1,510	0.53	14,010	1,945	0.72	18,045
	7,500	1,510	0.53	14,010	1,445	0.54	13,395	1,510	0.53	14,010	1,755	0.65	16,280
WSW24x11	1,000	3,295	0.53	22,485	3,490	0.58	23,830	3,295	0.53	22,485	4,100	0.69	27,985
	4,000	3,295	0.53	22,485	3,260	0.55	22,240	3,295	0.53	22,485	3,865	0.65	26,395

PROJECT:		SHEET NO.
BY:	DATE: 12/19	18/30
JOB NO.		

GARAGE ROOF

$l = 16'$

$W = .045(12) = 154 \text{ lb}$

$M = \frac{.54(16)^2}{8} = 207 \text{ K}''$

Sizes $\frac{207}{2.4(1.1)} = 78 \text{ lb}$
5 1/2" x 15" G

$l = 6'$

$W = .54 \text{ K}$

$M = \frac{.54(6)^2}{8} = 29.2 \text{ K}''$

Sizes $\frac{29.2}{2.4(1.1)} = 11 \text{ lb}$
5 1/2" x 9" G

FLOOR

$l = 6'$

$W = (.04 + .01 + .05)(11) = 1.1 \text{ K}$

$M = \frac{1.1(6)^2}{8} = 59.4 \text{ K}''$

Sizes $\frac{59.4}{2.4} = 25 \text{ lb}$
5 1/2" x 9" G

PROJECT:		SHEET NO.	
BY:	DATE:	JOB NO.	19/30
		7147	

CANALS

h=8' - 50k HORIZ BRW CAR

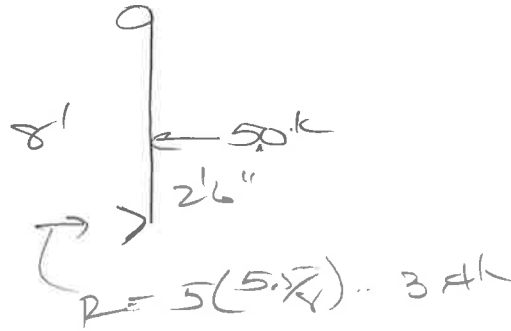

$$M = 3A(2.5)12 = 103k''$$

$$S_{reqd} = \frac{103}{1.6(1.05)} = 61.3$$

(5) 2x5 DPA2

HANGER

HUBS -
2.1(1.6) - 3.4 - OK

USE HSS 8x2x1/4 BUMPER

l=21' CANAL FLOOR

$$W = (1.07 + 0.01 + 0.05) = 0.18$$

$$M = \frac{0.1(21)^2}{8} P = 66.1k''$$

$$S_{reqd} = \frac{66.1}{2.4} = 28.6k''$$

P = 3.0k ON 9.5" Φ - THIS WILL SPREAD ONE (3) JOISTS W/ 4" C/W

$$M = \left[\frac{(1.05 + 0.01)}{8} 21^2 + \frac{(3.0 \times 21)}{4} \right] P = 102.7k''$$

$$S_{reqd} = \frac{102.7}{2.4} = 42.8k'' \quad 13/4" \times 19" W/C OK$$

PROJECT:			SHEET NO.
BY:	DATE:	JOB NO.	20/30
		17147	

$$L = 12'$$

$$W = 1.05(11+5) + 1.1 + 1.59 = 299k$$

$$M = \frac{29(12)^2}{8} = 518k'$$

$$S_{REQ} = \frac{518}{21.6} = 24 \rightarrow$$

W10x33

$$P = 299(21/2) = 25.6k \quad \text{USE (3) } 4'' \text{ PIPE PILES}$$

$$h = 20' \quad \text{USE A55 } 8 \times 8 \times 1/4$$

$$C_{XP} = 132k - OK$$

Table 4-4 (continued)
Available Strength in
Axial Compression, kips
Square HSS



HSS9-HSS8

$F_y = 46$ ksi

Shape	HSS9×9×												HSS8×8×											
	$3/16^c$				$1/8^c$				$5/8$				$1/2$				$3/8$				$5/16$			
	P_n/Ω_c	$\phi_c P_n$	LRFD	ASD	P_n/Ω_c	$\phi_c P_n$	LRFD	ASD	P_n/Ω_c	$\phi_c P_n$	LRFD	ASD	P_n/Ω_c	$\phi_c P_n$	LRFD	ASD	P_n/Ω_c	$\phi_c P_n$	LRFD	ASD	P_n/Ω_c	$\phi_c P_n$	LRFD	ASD
0	134	201	64.4	96.8	452	679	372	559	286	431	241	363												
6	132	198	63.8	95.9	434	653	358	538	276	415	233	350												
7	131	197	63.6	95.6	428	644	353	531	273	410	230	346												
8	130	196	63.4	95.2	421	633	348	523	269	404	226	340												
9	130	195	63.1	94.8	414	622	342	513	264	397	223	335												
10	129	193	62.8	94.4	405	609	335	503	259	389	219	329												
11	128	192	62.4	93.9	396	596	328	492	254	381	214	322												
12	126	190	62.1	93.3	386	581	320	481	248	372	209	315												
13	125	188	61.7	92.7	376	565	311	468	242	363	204	307												
14	124	186	61.2	92.0	365	549	303	455	235	353	199	299												
15	122	184	60.7	91.3	354	532	294	441	228	343	193	290												
16	120	181	60.2	90.5	342	514	284	427	221	333	187	282												
17	119	178	59.7	89.7	330	496	275	413	214	322	181	273												
18	117	176	59.1	88.8	318	478	265	398	207	311	175	263												
19	115	173	58.5	87.9	306	459	255	383	199	299	169	254												
20	113	170	57.8	86.9	293	440	245	367	191	288	162	244												
21	111	166	57.1	85.9	280	421	234	352	184	276	156	234												
22	108	163	56.4	84.2	267	402	224	337	176	264	150	225												
23	106	159	55.6	83.6	255	383	214	321	168	253	143	215												
24	103	155	54.8	82.4	242	364	203	306	160	241	137	205												
25	101	151	54.0	81.1	230	345	193	290	153	229	130	195												
26	97.7	147	53.1	79.8	217	326	183	275	145	218	124	186												
27	94.7	142	52.1	78.3	205	308	173	260	137	206	117	176												
28	91.6	138	51.1	76.9	193	290	163	246	130	195	111	167												
29	88.4	133	50.1	75.3	182	273	154	231	123	184	105	158												
30	84.9	128	49.0	73.7	170	256	145	217	116	174	99.1	149												
32	77.3	116	46.7	70.2	149	225	127	191	102	153	87.5	131												
34	70.0	105	44.2	66.4	132	199	113	169	90.2	136	77.5	116												
36	62.9	94.5	41.4	62.2	118	177	100	151	80.5	121	69.1	104												
38	56.5	84.9	38.4	57.7	106	159	90.2	136	72.2	109	62.0	93.2												
40	51.0	76.6	35.0	52.6	95.6	144	81.4	122	65.2	98.0	56.0	84.1												

Properties

A_g , in. ²	6.06	4.09	13.5	10.4	8.76
$I_x = I_y$, in. ⁴	78.2	53.5	125	100	85.6
$r_x = r_y$, in.	3.59	3.62	2.99	3.10	3.13
$\Omega_c = 1.67$	LRFD	ASD	$\phi_c = 0.90$		

^c Shape is slender for compression with $F_y = 46$ ksi.

Table 4-4 (continued)
Available Strength in
Axial Compression, kips
Square HSS



HSS8-HSS7

$F_y = 46$ ksi

Shape	HSS8×8×												HSS7×7×											
	$1/4$				$3/16^c$				$1/8^c$				$5/8$				$1/2$				$3/8$			
	P_n/Ω_c	$\phi_c P_n$	LRFD	ASD	P_n/Ω_c	$\phi_c P_n$	LRFD	ASD	P_n/Ω_c	$\phi_c P_n$	LRFD	ASD	P_n/Ω_c	$\phi_c P_n$	LRFD	ASD	P_n/Ω_c	$\phi_c P_n$	LRFD	ASD	P_n/Ω_c	$\phi_c P_n$	LRFD	ASD
0	196	294	130	195	63.0	94.7	386	580	320	480	247	371												
6	189	284	127	191	62.2	93.5	366	550	304	457	235	354												
7	186	280	126	190	61.9	93.0	359	540	298	448	231	348												
8	184	276	125	188	61.6	92.5	351	528	292	439	227	341												
9	181	272	124	186	61.2	92.0	343	515	285	429	222	333												
10	177	267	122	184	60.8	91.3	333	501	278	417	216	325												
11	174	261	121	182	60.3	90.6	323	486	270	405	210	316												
12	170	255	119	179	59.7	89.8	313	470	261	393	204	306												
13	166	249	117	176	59.2	88.9	302	453	252	379	197	296												
14	162	243	115	174	58.5	88.0	290	436	243	365	190	286												
15	157	236	113	170	57.9	87.0	278	418	233	350	183	275												
16	152	229	111	167	57.2	85.9	266	399	223	336	175	264												
17	147	222	109	163	56.4	84.7	253	381	213	320	168	252												
18	143	214	106	159	55.6	83.5	241	362	203	305	160	241												
19	137	207	103	155	54.7	82.2	228	343	193	290	152	229												
20	132	199	100	151	53.7	80.8	215	324	182	274	145	217												
21	127	191	97.0	146	52.7	79.3	203	305	172	259	137	206												
22	122	183	93.0	140	51.7	77.7	191	287	162	244	129	194												
23	117	175	89.1	134	50.6	76.0	179	268	152	229	122	183												
24	111	168	85.2	128	49.4	74.3	167	251	143	214	114	172												
25	106	160	81.3	122	48.2	72.4	155	233	133	200	107	161												
26	101	152	77.4	116	46.9	70.5	144	216	124	186	100	150												
27	96.0	144	73.6	111	45.5	68.4	133	201	115	173	92.9	140												
28	91.0	137	69.8	105	44.1	66.2	124	186	107	161	86.4	130												
29	86.0	129	66.1	99.3	42.6	64.0	116	174	99.6	150	80.6	121												
30	81.2	122	62.5	93.9	41.0	61.6	108	162	93.1	140	75.3	113												
32	71.8	108	55.4	83.2	37.5	56.4	95.0	143	81.8	123	66.2	99.4												
34	63.6	95.6	49.0	73.7	33.7	50.6	84.1	126	72.4	109	58.6	88.1												
36	56.7	85.3	43.7	65.7	30.0	45.2	75.1	113	64.6	97.1	52.3	78.6												
38	50.9	76.5	39.3	59.0	27.0	40.5	67.4	101	58.0	87.2	46.9	70.5												
40	46.0	69.1	35.4	53.2	24.3	36.6	60.8	91.4	52.3	78.7	42.3	63.6												

Effective length, KL (ft), with respect to least radius of gyration, r_y

Properties

A_g , in. ²	7.10	5.37	14.0	11.6	8.97
$I_x = I_y$, in. ⁴	70.7	54.4	93.4	80.5	65.0
$r_x = r_y$, in.	3.15	3.18	2.58	2.63	2.69
$\Omega_c = 1.67$	LRFD	ASD	$\phi_c = 0.90$		

^c Shape is slender for compression with $F_y = 46$ ksi.

#7777 27/30

Recommended Earth Pressures for Cantilever Wall

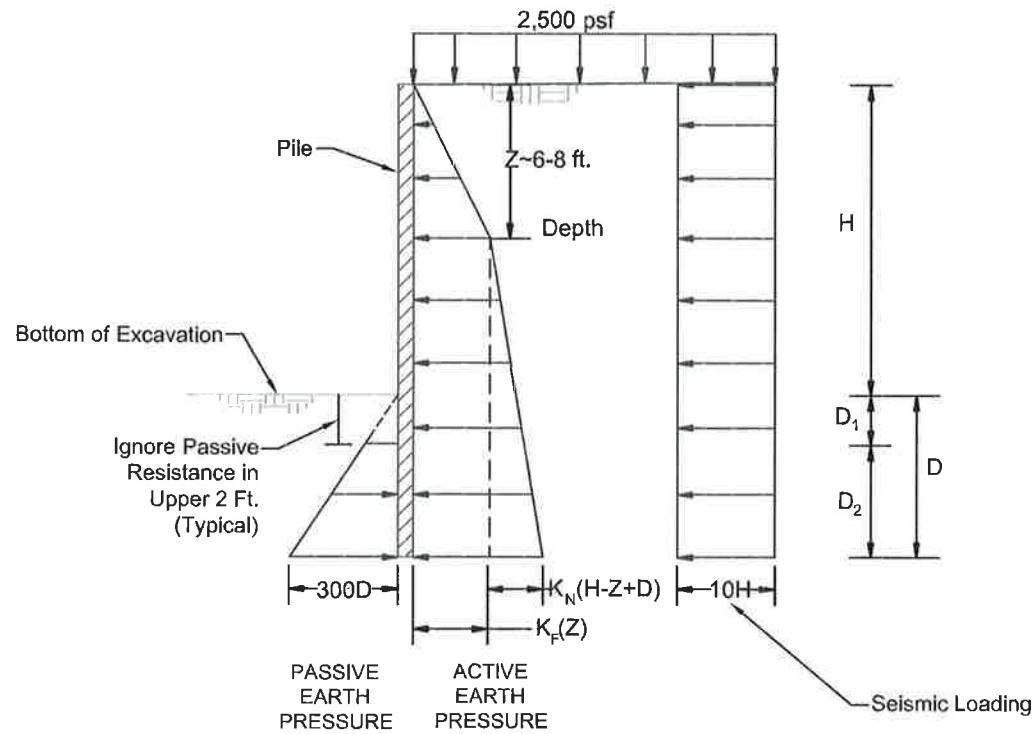

Recommended Earth Pressures for Single Braced Wall

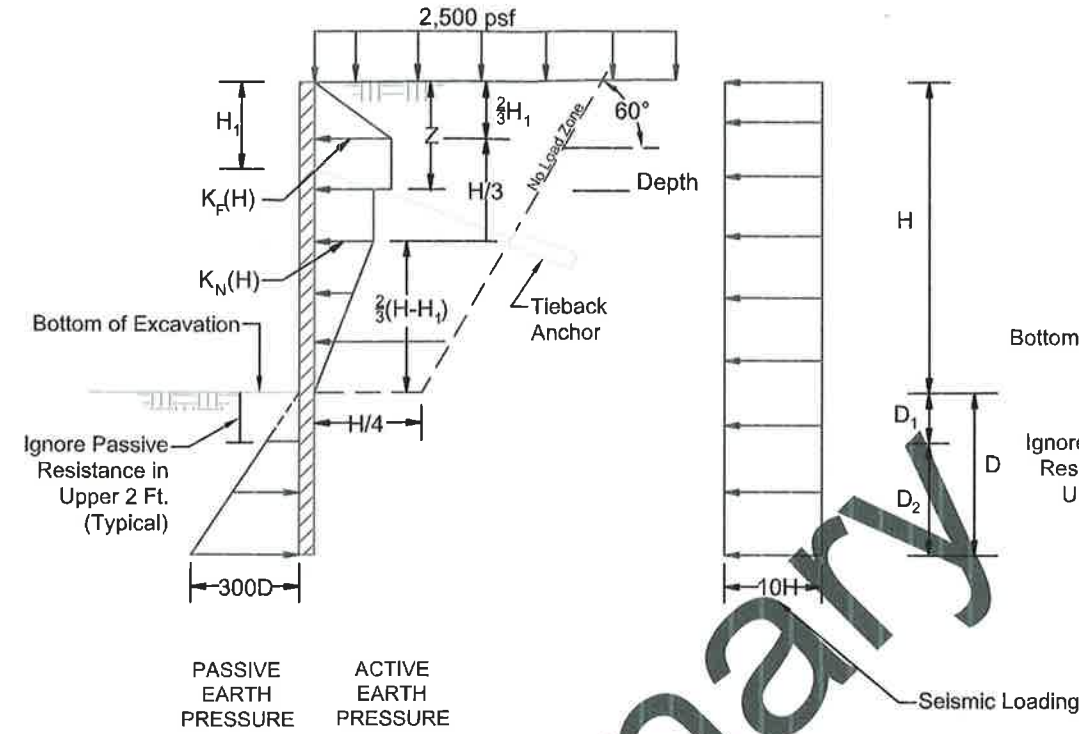

Recommended Earth Pressures for Multiple Braced Wall

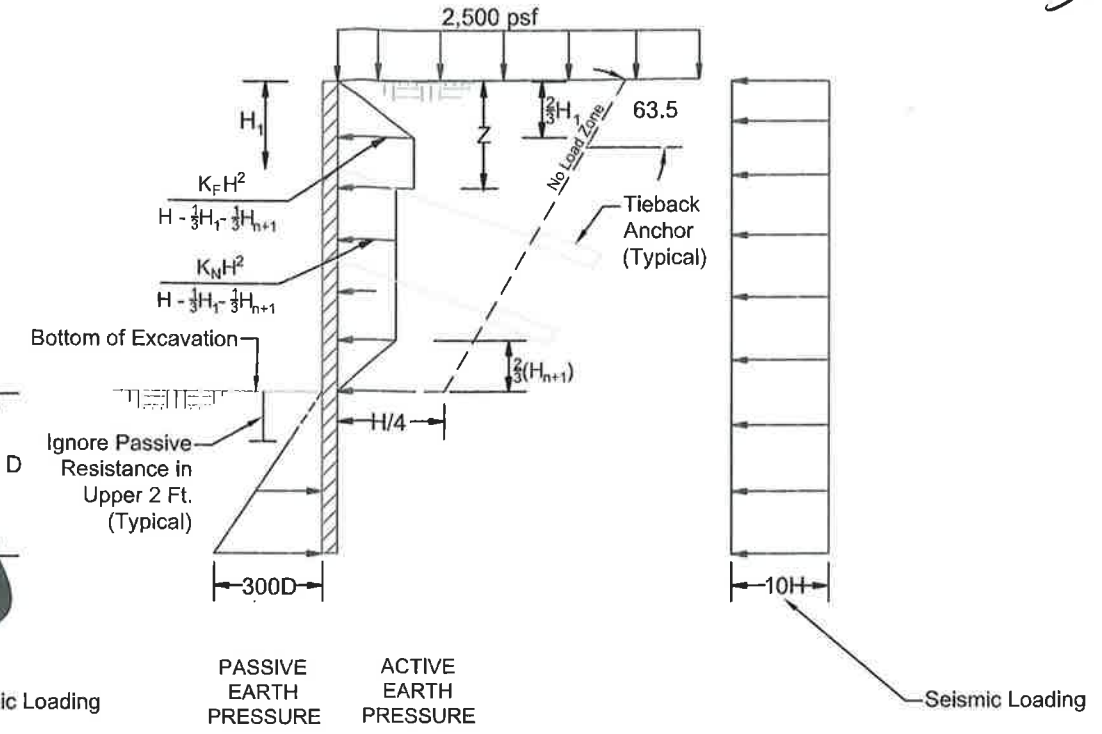

NOTES

- All Earth pressures are in units of pounds per square foot.
- Wall embedment (D) should consider kickout resistance. Embedment should be determined by satisfying horizontal static equilibrium about the bottom of the pile. Minimum recommended embedment is 5 feet.
- Passive pressures include FS = 1.5.
- Surface surcharge of 2,500 psf accounts for the slope above the proposed excavation.
- The recommended pressure diagrams are based on a continuous wall system. If soldier piles with laggings are used, apply active pressure over the width of the soldier piles below bottom of excavation and apply passive resistance over twice the width of the piles or the spacing of the piles, whichever is smaller.
- Free drainage assumed behind the wall.
- Design lagging for 30% of lateral earth pressure if span is 8 ft or less.
- Allowable vertical soldier pile capacity:
Skin Friction = 1.0 ksf
End Bearing = 5 ksf
(After loose/disturbed soil at bottom of hole is removed and if piles are utilized)
- Allowable transfer load for a 6-inch diameter soil anchor that is gravity grouted = 2 klf
- Lateral earth pressure for surcharges due to traffic, construction equipment, and adjacent foundations should be determined based on Figure 5.
- Seismic surcharge should be applied for permanent structures where required by code.

LEGEND

- H Excavation Height (Ft.)
- H₁ Depth to Uppermost Brace Level (Ft.)
- H_s Equivalent Surcharge Height (Ft.)
H_s minimum = 2 Feet
- H_{n+1} Distance from Base of Excavation to Lowermost Brace Level
- D, D₁, D₂ Embedment Depths (Ft.)
- Z Depth of Fill/Weathered Soil, About 6-8 ft.
- K_{FA} Active Earth Pressure - Fill/Weathered Zone
- K_{FO} At-Rest Earth Pressure - Fill/Weathered Zone
- K_{NA} Active Earth Pressure - Native
- K_{NO} At-Rest Earth Pressure - Native

RECOMMENDED EARTH PRESSURES

System	Depth (Ft.)	Above		Below	
		K _{FA}	K _{FO}	K _{NA}	K _{NO}
Cantilever/Single Brace	Z	32	51	30	46
Multiple Brace	Z	22	34	20	31

Lateral Earth Pressures
Proposed Single Family Residence
6303 West Mercer Way
Mercer Island, Washington

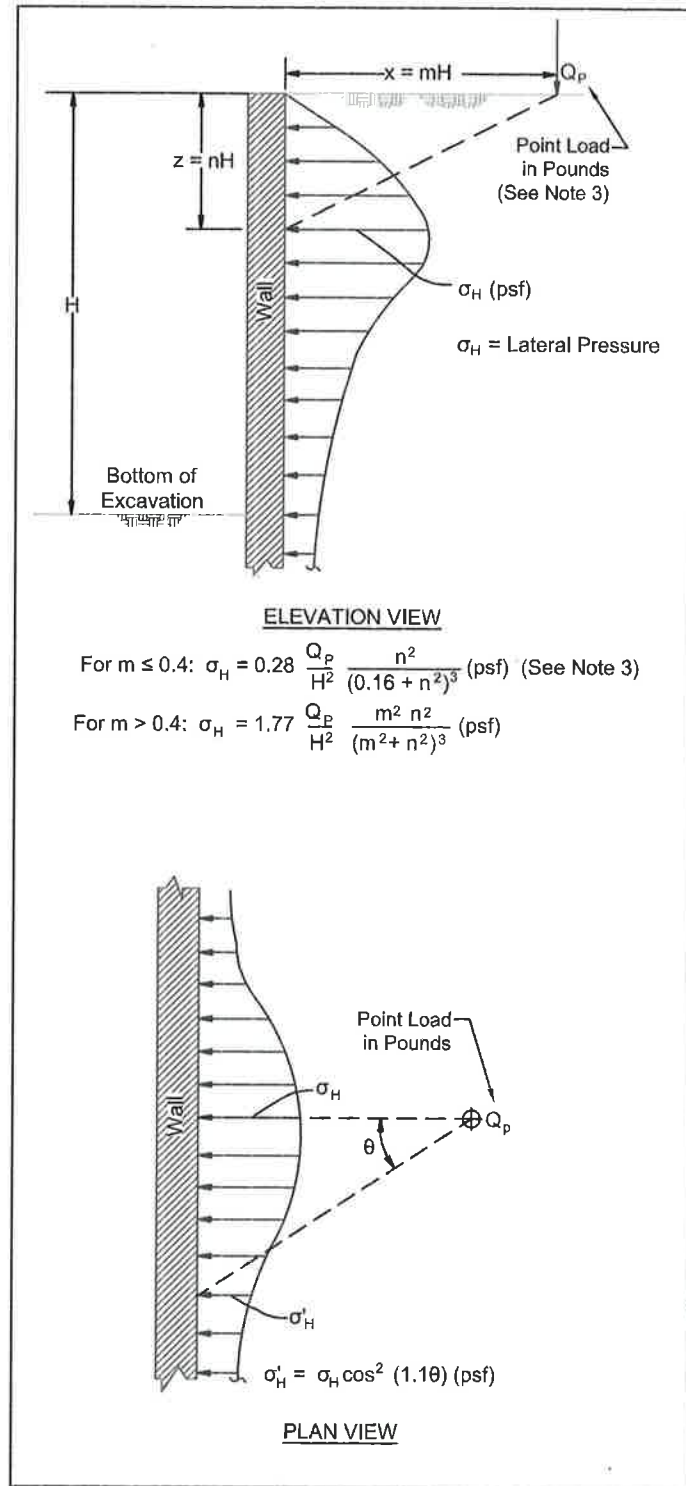

A) LATERAL PRESSURE DUE TO POINT LOAD
i.e. SMALL ISOLATED FOOTING OR WHEEL LOAD
(NAVFAC DM 7.2, 1986)

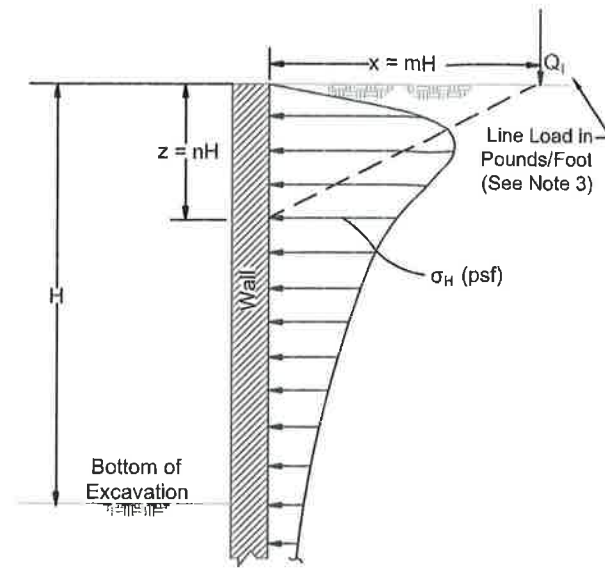

B) LATERAL PRESSURE DUE TO LINE LOAD
i.e. NARROW CONTINUOUS FOOTING
PARALLEL TO WALL
(NAVFAC DM 7.2, 1986)

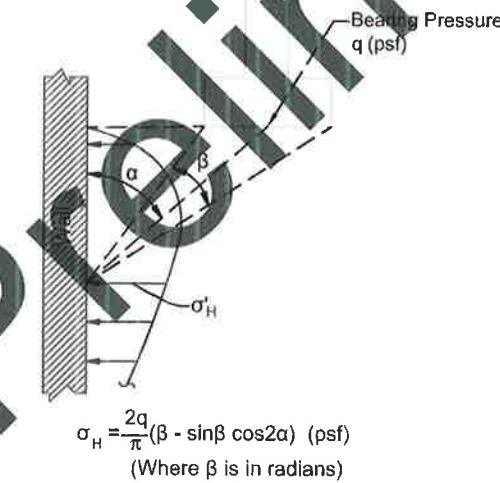

C) LATERAL PRESSURE DUE TO STRIP LOAD
(DERIVED FROM FANG, FOUNDATION
ENGINEERING HANDBOOK, 1991)

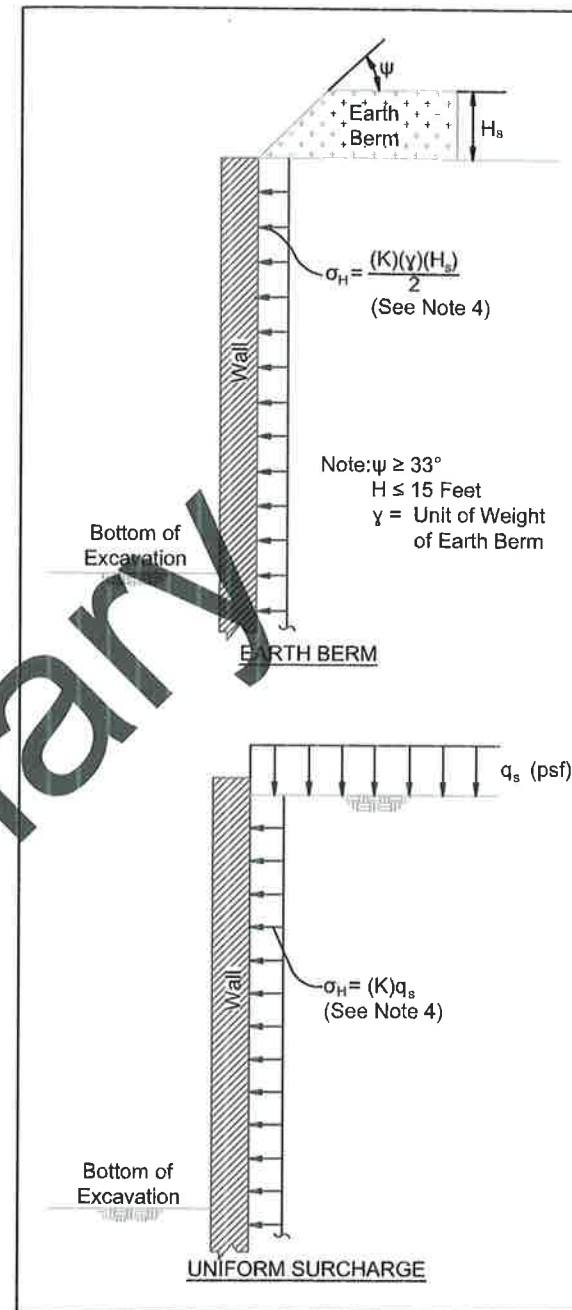

D) LATERAL PRESSURE DUE TO EARTH BERM
OR UNIFORM SURCHARGE

(DERIVED FROM POULOS AND DAVIS, *ELASTIC SOLUTIONS FOR SOIL AND ROCK MECHANICS*, 1974; AND TERZAGHI AND PECK, *SOIL MECHANICS IN ENGINEERING PRACTICE*, 1967)

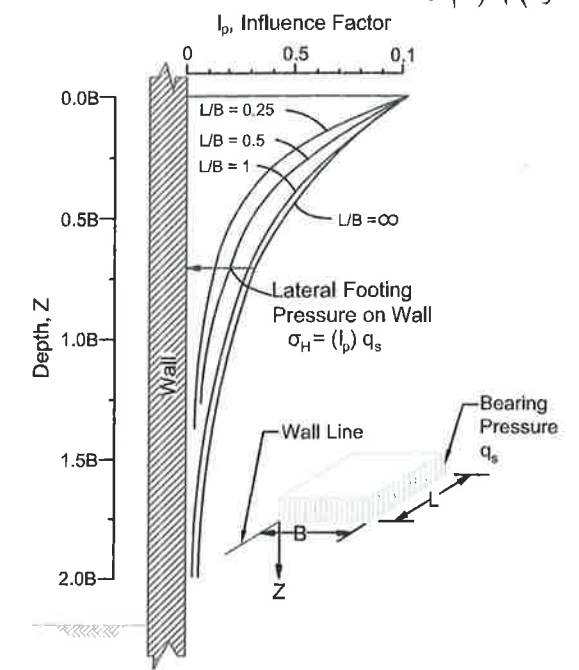

E) LATERAL PRESSURE DUE TO ADJACENT FOOTING
(DERIVED FROM NAVFAC DM 7.2, 1986; AND SANDHU, *EARTH PRESSURE ON WALLS DUE TO SURCHARGE*, 1974)

NOTES

- FIGURES ARE NOT DRAWN TO SCALE.
- APPLICABLE SURCHARGE PRESSURES SHOULD BE ADDED TO THE APPROPRIATE PERMANENT WALL LATERAL EARTH AND WATER PRESSURE.
- IF POINT OR LINE LOADS ARE CLOSE TO THE BACK OF THE WALL SUCH THAT $m \leq 0.4$, IT MAY BE MORE APPROPRIATE TO MODEL THE ACTUAL LOAD DISTRIBUTION (i.e., DETAIL E) OR USE MORE RIGOROUS METHODS.
- $K_a = 0.25$, $K_o = 0.4$

GEORESOURCES
earth science & geotechnical engineering
5007 Pacific Hwy E., Suite 16 | Fife, WA 98424 | 253.896.1011 | www.georesources.rocks

Lateral Earth Pressure Surcharges
Proposed Single Family Residence
6303 West Mercer Way
Mercer Island, Washington

PROJECT:		SHEET NO.
BY:	DATE:	JOB NO. 1749
		24 30

WALKWAY VAULT

$$W = 8(12) = 96 \text{ kft}$$

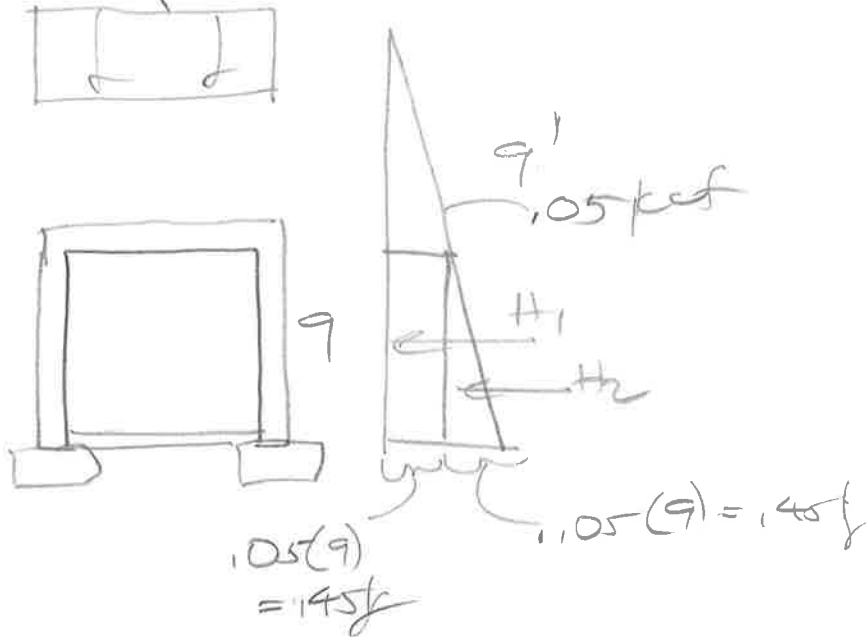

HAUS

$$H_1 = 1.45(9) = 13.05 \text{ k}$$

$$H_2 = 1.45(9) \cdot \frac{1}{2} = 6.525 \text{ k}$$

$$M = \left(\frac{1.45(9)^2}{8} \right) + \left(\frac{1.45(9)}{2} \right) \cdot 9 = 82.9 \text{ k}''$$

4.6 2.3

$$R_v = \frac{82.9(1.6)}{19(12)(5)^2} = 1.49 \text{ ksi} \quad f_c = 1.0094$$

$$A_s = 1.0094(12)(5) = 156 \text{ in}^2 \cdot \frac{1}{8} = 6 \text{ in}^2$$

#6 @ 9 in

LD

$$M = 1.94(8)^2 \cdot \frac{1}{8} = 92.2 \text{ k}''$$

$$R_v = \frac{92.2(1.6)}{19(12)(10)^2} = 1.14 \text{ ksi}$$

$$A_s = 1.00332(12)(10) = 1.4 \text{ in}^2$$

PROJECT:			SHEET NO.
BY:	DATE:	JOB NO.	257 30
		1747	

$$M = .186(2.33)12$$

ON
RETAINING

$$= 24.06''$$

$$P_u = \frac{24(1.4)}{.9(12)10^2} = 1035 \text{ (k)}'$$

$$A_s = 1.00373 \left(\frac{35}{200} \right) 11.5 (12) 10 = 1106'$$

#5 @ 12" L

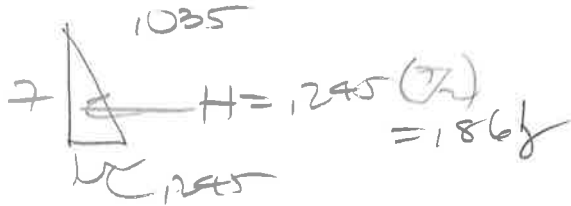

#1742

24/30

118

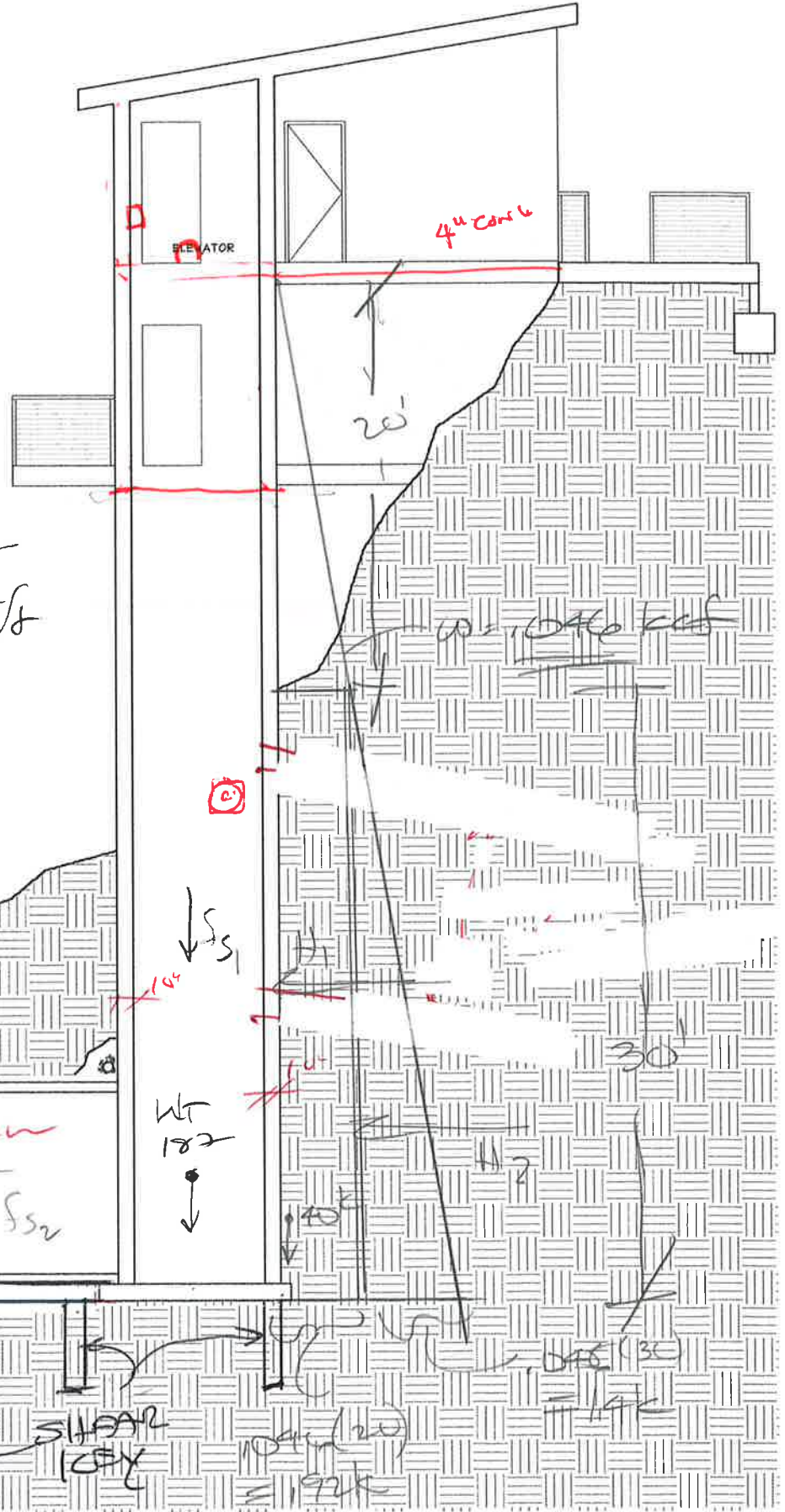

$$H_1 = 92(30) = 27.6 \text{ k/ft}$$

$$H_2 = 14(30) = 4.2 \text{ k/ft}$$

W = 1040 lbs

WATER PROOFING
4" PEA GRAVEL

110cm
HTK
92'
BLAB

SS
WT 182

10'

SHEAR
100X

1040(20)
= 20800

14K

11150 Gravelly Lake Drive SW
Lakewood, WA 98499
Phone: 253/581-6000
Website: www.jgarch.net

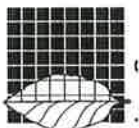

BOYLE MERCER ISLAND

BI III DINIC SECTION

PRELIMINARY

DATE DATE
REVISED

SHEET NO.

A3.2

SCALE FACTOR: 48

PROJECT:		SHEET NO.	
BY:	DATE:	JOB NO. 17447	27 30

CHECK SLAFT STABILITY

$$H_{1\text{TOTAL}} = 27.6(9) = 248k$$

$$H_{2\text{TOTAL}} = 21(9) = 189k$$

$\Sigma = 437$

$$W_{T\text{SHAFT}} = 1.9/2(115)36(40) + 1.01(36)20 = 187k$$

$$W_{T\text{VAULT}} = 1.9/2(115)29(20) + 1.12(8)20 = 91.7k$$

$$W_{T\text{FTC}} = 1.25(15)11(29) = 59.8k$$

$$W_{T\text{SOIL}} = .12(11)30 = 39.6k$$

$$\Sigma = 378k$$

$$f_1 = 233k$$

$$f_2 = 124k$$

$$f_3 = 97.2k$$

$$\phi = 13(1.5) = 19.5$$

$\Sigma f_1, f_2, f_3$
1493.7

$$\rightarrow 378(1.45) + 233 + 124 + 97.2 = 624k$$

$$OT = 92(10) + 245(187) + 59.8(14.5) + 40(28) + 233(24.5) + 124(10)$$

$$(248)15 + 189(10)$$

$$= 2.6 < 1.5$$

$$SLIDING = \frac{624}{437} = 1.43 < 1.5$$

O.K. CLOSE (USE 9' OF WALL WIDTH - ONLY 8')
SO CONSERVATIVE

PROJECT:		SHEET NO. 28/30	
BY:	DATE:	JOB NO. 1797	

SHEAR KEY

13(115)
= 1,45 kcf
PASSIVE

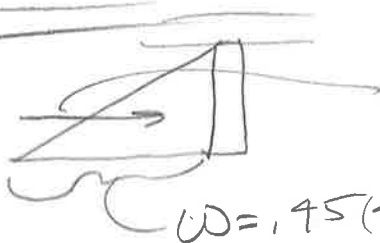

$W = 1.45(4) = 1.18 \text{ k}$

$f_{sk} =$
 $W_p = 1.18(4)9 = 32.4 \text{ k}$
 $f_{sk} = 32.4(3) = 97.2 \text{ k}$ (3 SHEAR KEYS)

SIDEWALL FRICTION

$f_{s2} = 276(195)$
 $= 124 \text{ k}$

$W_2 = .46(10)20(2)$
 $= 184$

$W_3 = .46(10)2(2)$
 $= 92$



$.096(10)$
 $= .46$

$.46(10)$
 $= .46$

$f_{s1} = 518(195)$
 $= 233 \text{ k}$

$W_1 = 1.15(20)9(2)$
 $= 518 \text{ k}$



$.096(20) = 1.15$

$\Sigma = 518 + 184 + 92 = 794 \text{ k (195)}$
 $= 357 \text{ k}$

PROJECT:		SHEET NO. 29 / 30	
BY:	DATE:	JOB NO. 17142	

SHAR ICEM

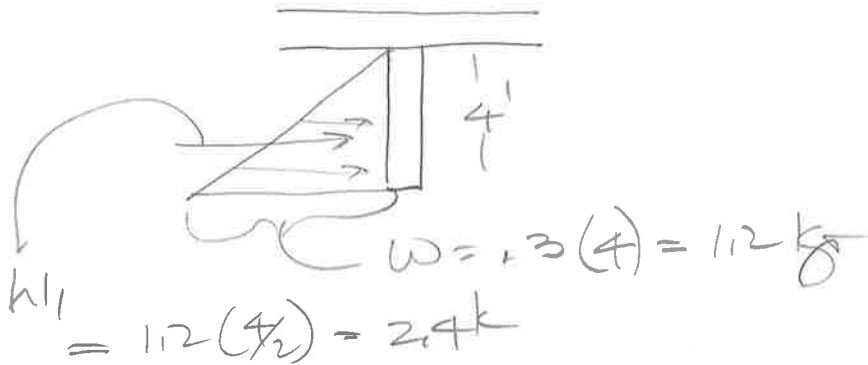

$$M_U = 1.6(2.4)4(3/3)12 = 123 \text{ k}''$$

$$S_{reqd} = \frac{123}{1.9(12)5^2} = 145 \text{ ksc}''$$

$$A_s = .005(12)5 = 149 \text{ in}^2$$

#6 @ 10" CETERA

SHAFI

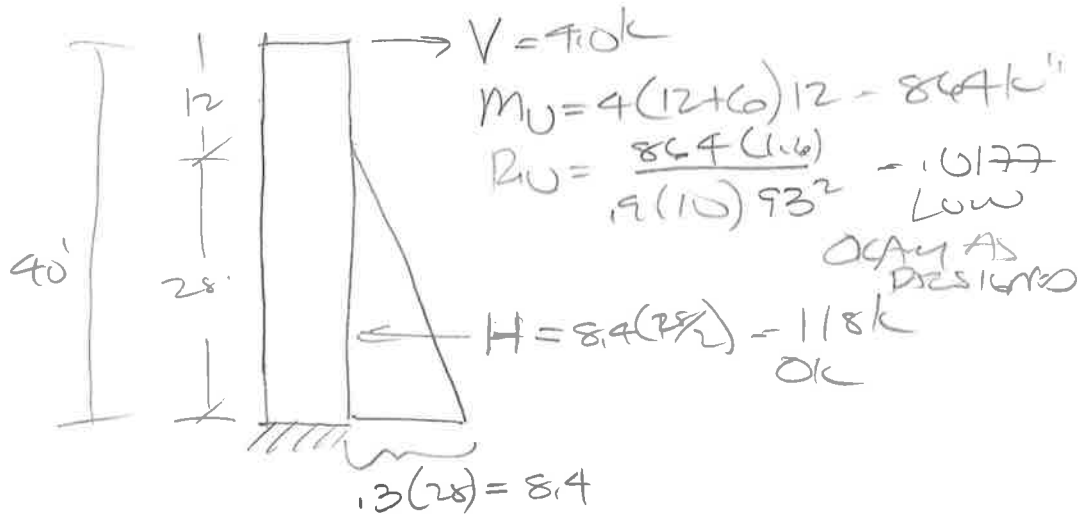

PROJECT:		SHEET NO. 30/30	
BY:	DATE:	JOB NO. 17147	

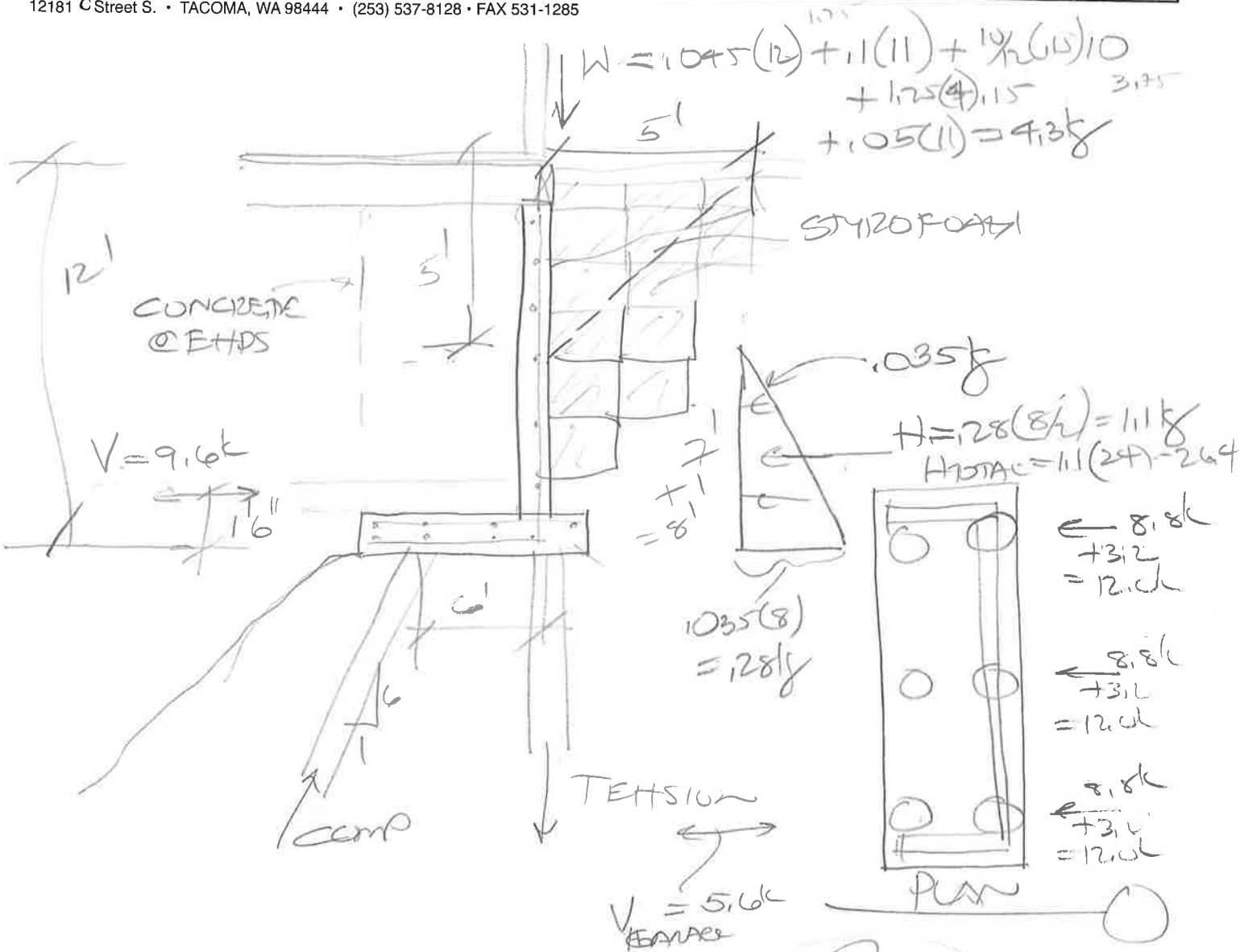

$$TORC = 8.8(3)23 + 9.6(11) / 6 = 12.5 / 3 = 4.2k$$

$$SHEAR = 12.0k$$



$$COMPRESSION IN PILE = 4.2 + 12(6) = 77.4k$$

$$+ 1.25(4)24 / 3 = 6k \text{ EXTRA PILES}$$

$$\Sigma = 83.4k = 62k$$